



AIRTECHNIC

www.airtechnic.gr

Air-Conditioning & Ventilation Components & Systems

Disc valves

PV

περισσότερα
learn more



Disc valves PV

Circular ceiling diffusers (disc valves) **PV** have a central disc that is supported by a screw and when it rotates it moves inwards (-) or outwards (+) varying the amount of air passing through the valve.

Depending on the type, they are manufactured from anodized aluminium, aluminium powder painted in RAL color, stainless steel and plastic PVC. They are designed for all types of air conditioning, ventilation, heating or cooling systems and are used in small spaces such as toilets, hallways and small rooms. They are suitable for installation on a ceiling, wall or air duct, for supply or return air, depending on the type.

The standard dimensions are : $\varnothing 100, 125, 150, 160$ & 200 .



DISC VALVES TYPES

- PV1** : Manufactured from **aluminium**, powder painted in RAL 9010 (white). Suitable for return air.
- PV2** : Manufactured from **aluminium**, powder painted in RAL 9010 (white). Suitable for supply air.
- PVI** : Manufactured from **stainless steel**. Suitable for return or supply air.
- PVP** : Manufactured from **plastic PVC**. Suitable for return air.

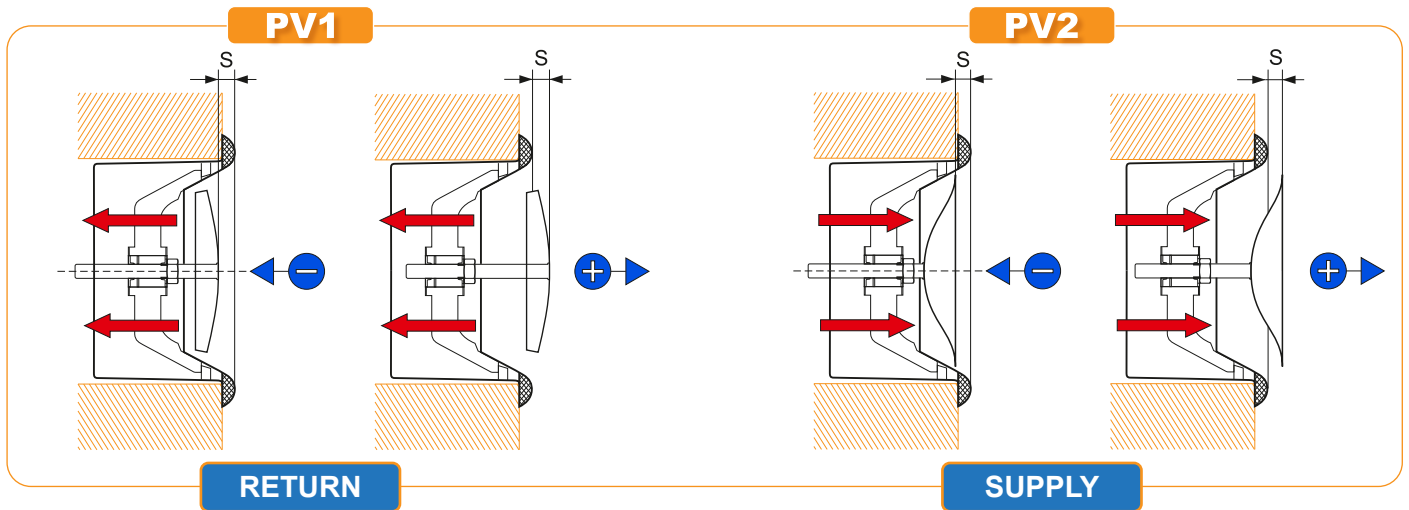

The frame is suitable for all types of installation (wall, ceiling or air duct). Between the frame and the valve there is foam sealant which guarantees **absolute air tightness** and firm placement of the disc valve.

Air flow adjustment:

The central disc is supported by a screw and when it rotates it moves **inwards (-) or outwards (+) varying the amount of air passing through the valve.**

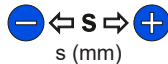

This also regulates the pressure drop and noise level of the diffuser.

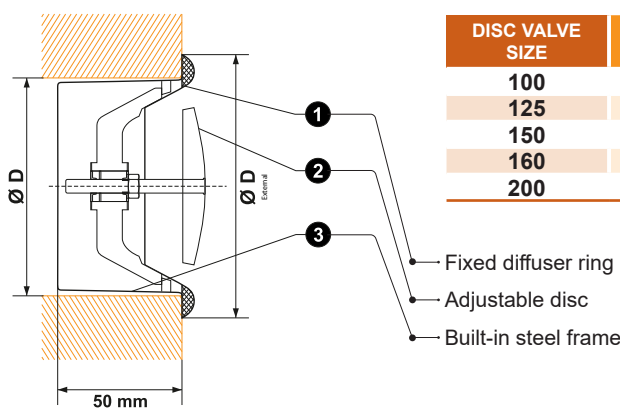

DISC VALVE SIZE	Ø D external	Ø D
100	138	97,5
125	164	122,5
150	202	147,5
160	211	157,5
200	248	197,5

Disc valves PV1 & PV2 can be powder painted in any RAL color, upon request. For the full range of RAL colors please contact us.



Color examples

DISC VALVES SIZE SELECTION

The selection of disc valves will be made using the following diagrams and in accordance with the guideline **CR 1752:1998** (Ventilation for buildings - Design criteria for the indoor environment).

The technical specifications for disc valves are the following :

Diffuser diameter	$\varnothing D$	[mm]
Maximum air velocity inside the diffuser	U_o	[m/s]
Pressure drop inside the diffuser	ΔP	[Pa]
Noise level	Θ	dB[A]
Air flow adjustment screw position	S	-/+ x
Horizontal stream range	X_o	[mm]
Horizontal stream velocity at distance X	U_T	[m/s]

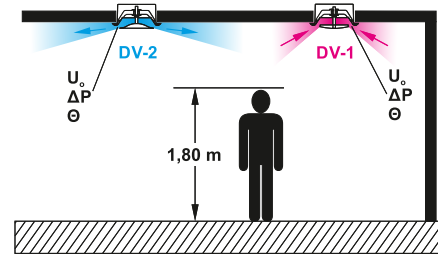

DISC VALVES ORDER

For the proper order of disc valves **PV** please use the following code :

PV1 - 100 - 9016	Disc valve color RAL... = Disc valve powder painted in RAL color Blank = According the disc valve's type
	Disc valve size
	Disc valve type PV1 = From aluminium , powder painted in RAL 9010. For return air. PV2 = From aluminium , powder painted in RAL 9010. For supply air. PVI = From stainless steel . For return or supply air. PVP = From plastic PVC . For return air.

Examples

PV2 - 150

Disc valve type PV2, for supply air, manufactured of aluminium painted in RAL 9010 (white), size 150.

PVP - 200

Disc valve type PVP, for return air, manufactured of plastic PVC, size 200.

SPECIFICATIONS



Circular, ceiling diffuser, disc valve for return air, PV1

Circular, ceiling diffuser, disc valve, indicative type **PV1** by **AIRTECHNIC**, manufactured of anodized aluminum / aluminum painted in RAL 9010 (white) color / in RAL... color with a central disc that is supported by a screw and when it rotates it moves inwards (-) or outwards (+) varying the amount of air passing through the valve. It will have foam seal between the frame and the valve for ultimate air tightness. The manufacturer will have performed measurements of the technical characteristics of the grille, in an independent laboratory. It will be suitable for wall, ceiling or air duct placement and use in small areas such as toilets, walkways and small rooms **for return air**. The factory will be certified according to **ISO 9001:2015** (Quality Management Systems) and according to **ISO 14001:2015** (Environmental Management Systems). It will be manufactured by **AIRTECHNIC** type **PV1**



Circular, ceiling diffuser, disc valve for supply air, PV2

Circular, ceiling diffuser, disc valve, indicative type **PV2** by **AIRTECHNIC**, manufactured of anodized aluminum / aluminum painted in RAL 9010 (white) color / in RAL... color with a central disc that is supported by a screw and when it rotates it moves inwards (-) or outwards (+) varying the amount of air passing through the valve. It will have foam seal between the frame and the valve for ultimate air tightness. The manufacturer will have performed measurements of the technical characteristics of the grille, in an independent laboratory. It will be suitable for wall, ceiling or air duct placement and use in small areas such as toilets, walkways and small rooms **for supply air**. The factory will be certified according to **ISO 9001:2015** (Quality Management Systems) and according to **ISO 14001:2015** (Environmental Management Systems). It will be manufactured by **AIRTECHNIC** type **PV2**



Circular, ceiling diffuser, disc valve for return or supply air, PVI

Circular, ceiling diffuser, disc valve, indicative type **PVI** by **AIRTECHNIC**, manufactured of stainless steel with a central disc that is supported by a screw and when it rotates it moves inwards (-) or outwards (+) varying the amount of air passing through the valve. It will have foam seal between the frame and the valve for ultimate air tightness. The manufacturer will have performed measurements of the technical characteristics of the grille, in an independent laboratory. It will be suitable for wall, ceiling or air duct placement and use in small areas such as toilets, walkways and small rooms **for return or supply air**. The factory will be certified according to **ISO 9001:2015** (Quality Management Systems) and according to **ISO 14001:2015** (Environmental Management Systems). It will be manufactured by **AIRTECHNIC** type **PVI**



Circular, ceiling diffuser, disc valve for return air, PVP

Circular, ceiling diffuser, disc valve, indicative type **PVP** by **AIRTECHNIC**, manufactured of plastic PVC with a central disc that is supported by a screw and when it rotates it moves inwards (-) or outwards (+) varying the amount of air passing through the valve. It will have foam seal between the frame and the valve for ultimate air tightness. The manufacturer will have performed measurements of the technical characteristics of the grille, in an independent laboratory. It will be suitable for wall, ceiling or air duct placement and use in small areas such as toilets, walkways and small rooms **for return air**. The factory will be certified according to **ISO 9001:2015** (Quality Management Systems) and according to **ISO 14001:2015** (Environmental Management Systems). It will be manufactured by **AIRTECHNIC** type **PVP**

PV1, PVP, PVI / for RETURN air - PRESSURE DROP & NOISE LEVEL CALCULATION

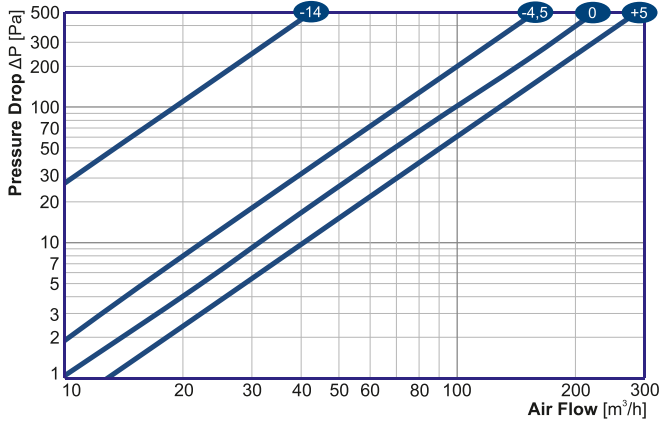

D100

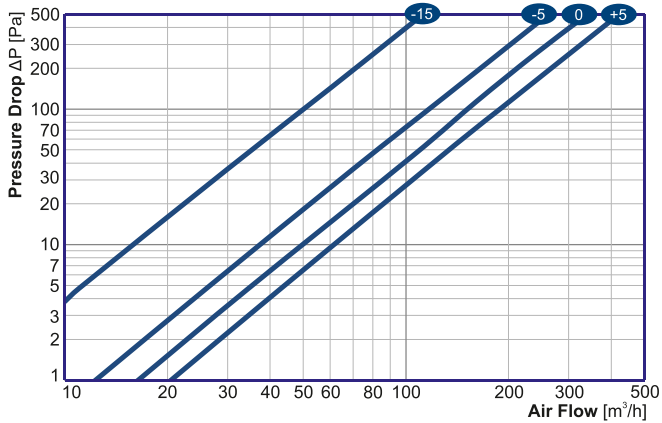
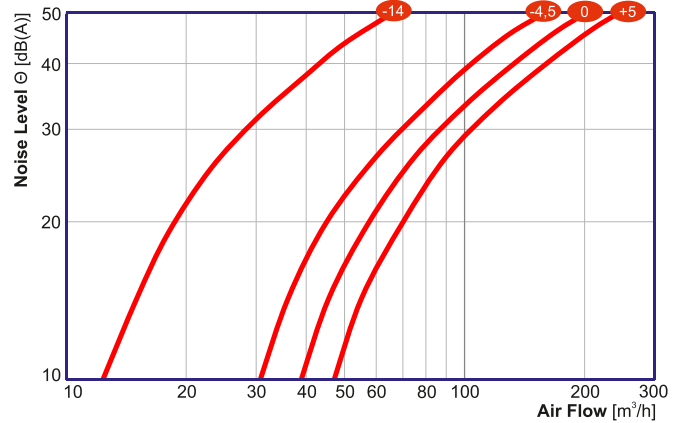

D125

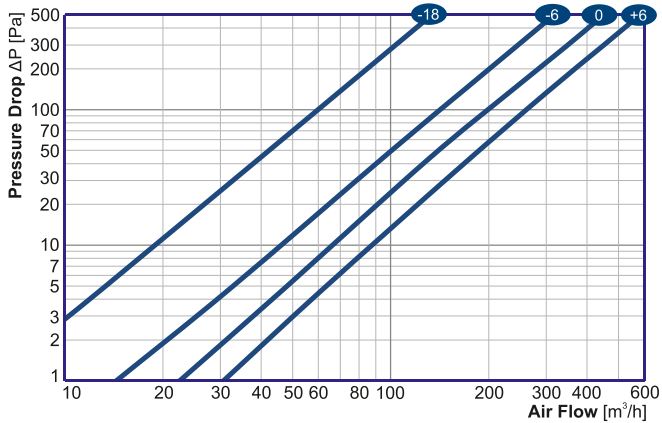
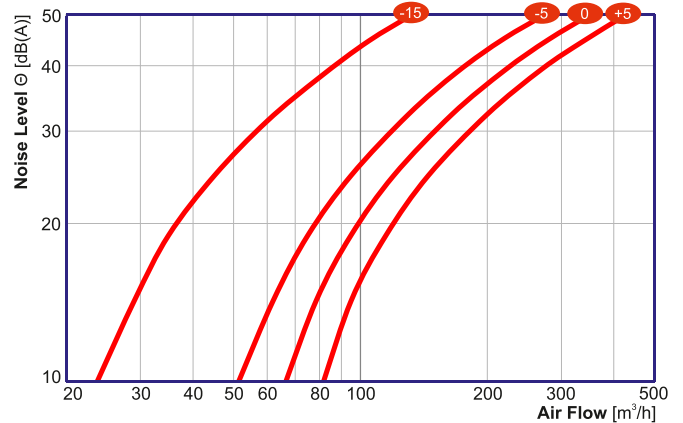

D160

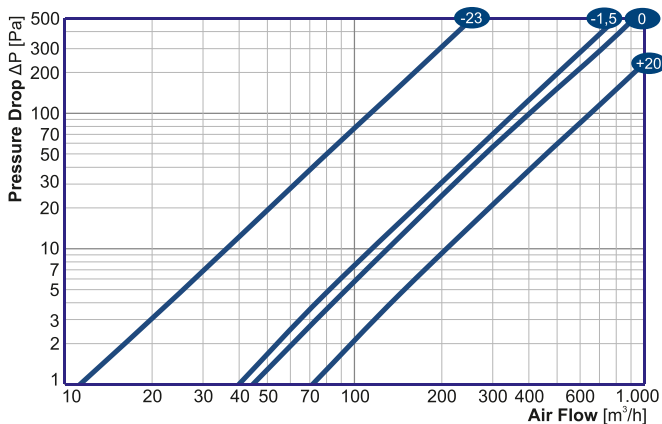
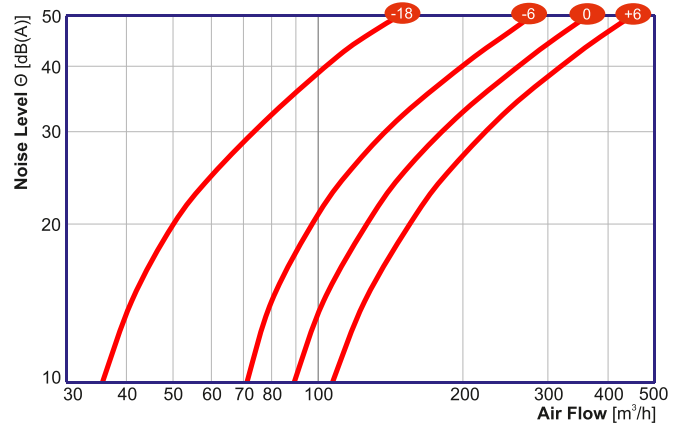

D200

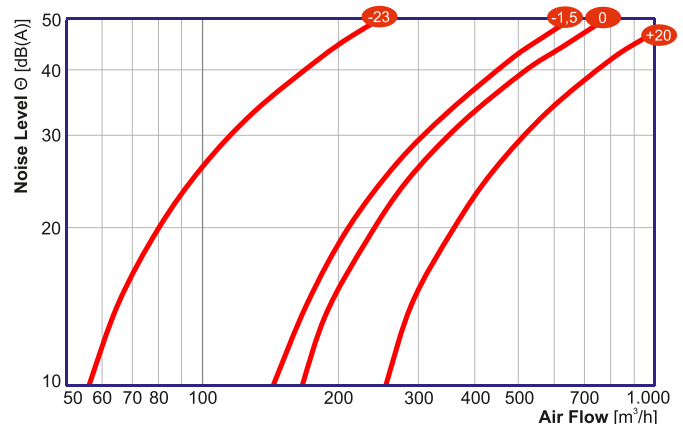

PV2, PVI / for SUPPLY air - PRESSURE DROP & NOISE LEVEL CALCULATION

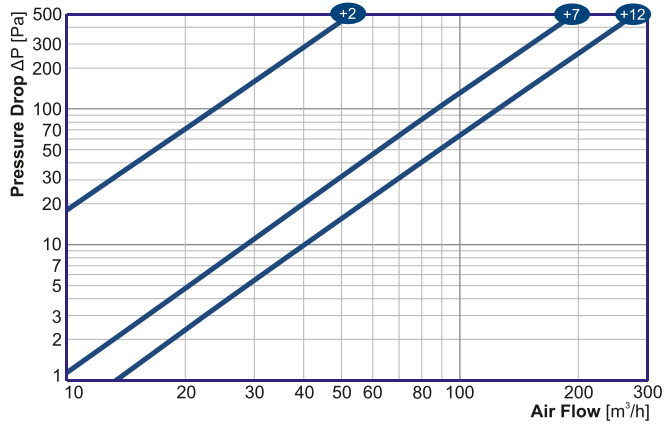
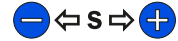

D100

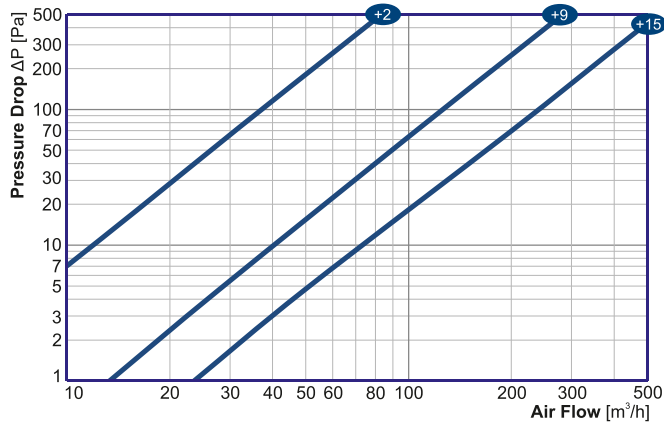
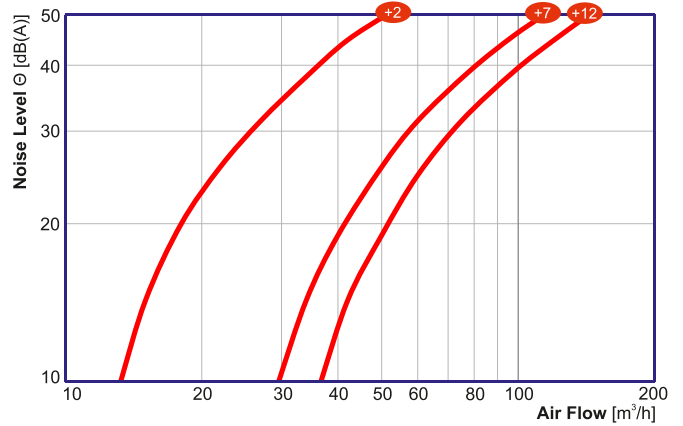

D125

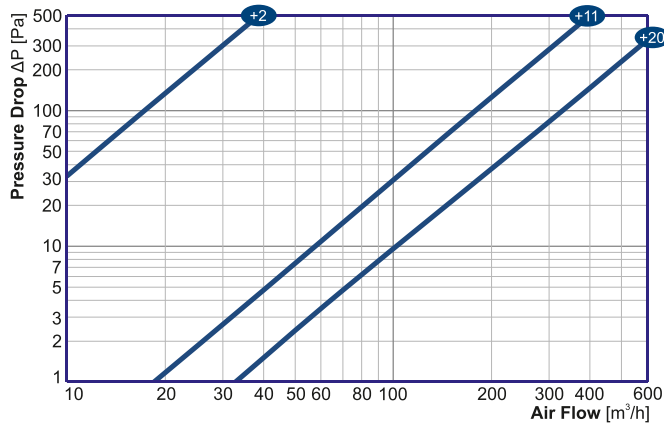
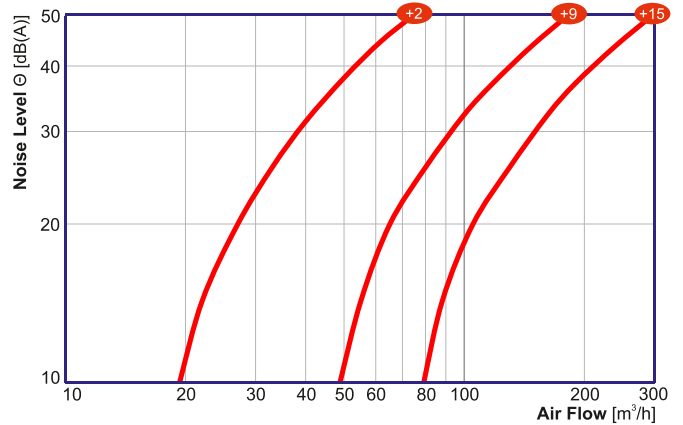

D160

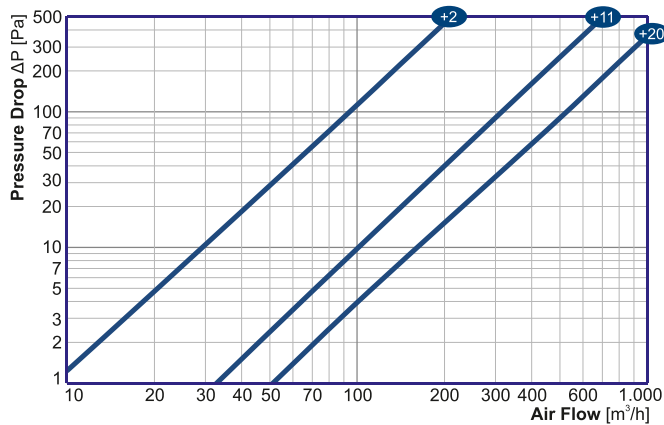
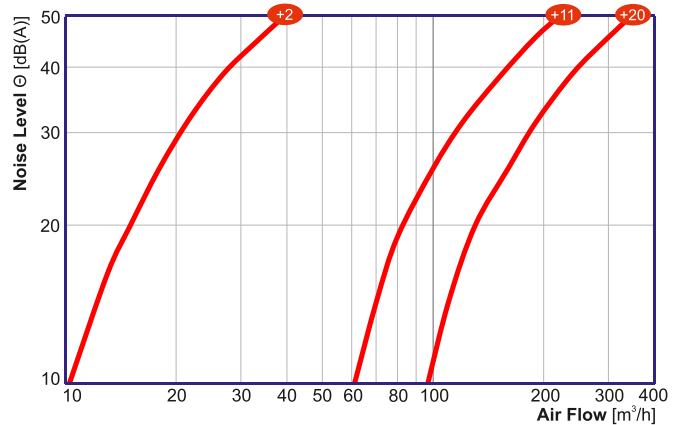

D200

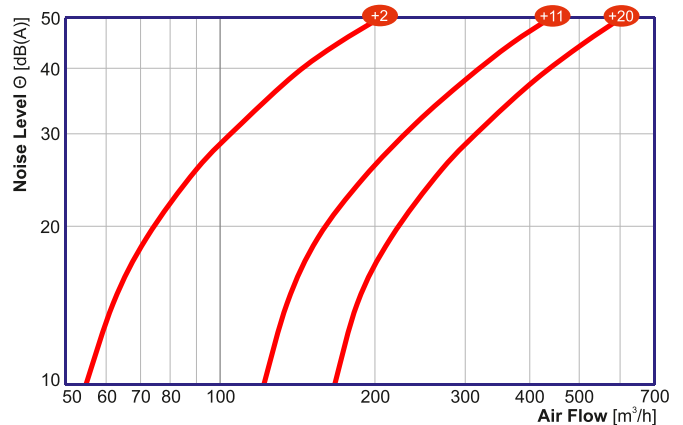



ISO 9001:2015



ISO 14001:2015

Management System
ISO 14001:2015
Valid until:
2024-05-24



www.tuv.com
ID: 9108660718

AIR HANDLING UNITS



HEAT EXCHANGERS



FAN COIL UNITS



FANS & FAN SECTIONS



FIRE DAMPERS



AIR OUTLETS



STEAM HUMIDIFIERS - DEHUMIDIFIERS



CENTRAL VACUUM SYSTEMS



TUBO
THINK CLEAN

STAINLESS STEEL CHIMNEYS



AIR FILTERS



AIR CURTAINS



EVAPORATIVE COOLING



Main Office ATHENS

📍 Paparrigopoulou 10 & Lagada,
12132, Peristeri, Athens
211 - 705.55.00
✉ sales@airtechnic.gr

Factory - THIVA

📍 4th km Thiva - Chalkida Hwy,
32200, Thiva
22620 - 89.006
✉ factory@airtechnic.gr

Factory - THESSALONIKI

📍 End of Meandrou Str.,
57013, Oraiokastro, Thessaloniki
2311 - 82.40.00
✉ thessaloniki@airtechnic.gr