



AIRTECHNIC

www.airtechnic.gr

Air-Conditioning & Ventilation Components & Systems

● **Energy Box**
PA · H & PA · V
PACKAGED TYPE HEAT RECOVERY UNIT

περισσότερα
learn more



 www.airtechnic.gr

 www.facebook.com/Airtechnic.gr

 www.instagram.com/airtechnic.chatzoudis

V. 4

ENERGY BOX PA·H & PA·V

Packaged Type Heat Recovery Unit

Index

Unit components.....	2	Accessories	
Performance data.....	3	Duct type electric heaters.....	7
Tech. specifications & dimensions.....	4	Duct type coils.....	8
Control system.....	5		



ENERGY BOX PA·H

ENERGY BOX PA·V

Control system Plug&Play

AIRTECHNIC control unit is developed for controlling of heat recovery units' equipments, meeting the demands coming from the customers and is user friendly designed. It's capable of controlling the basic and optional functions of the unit. The control unit can be switched on/off via BMS, can receive fault signals and can control all the functions via ModBus. Alternative controllers are listed in "Control System" part.

Exhaust and Supply Air Filters

To increase indoor air quality and to protect the equipments used in unit, F class filter (according to EN 779 standard) is used for supply air streams; M class filter is used for exhaust air streams. A choice of pre-filters (G2-G4) and final filters (F6-F9) are available optionally. Optional filters reduce the available static pressure of the unit.

Exhaust and supply air fans

The fans in heat recovery units are equipped with innovative Electronically Commutated EC motor technology. EC motors have higher efficiency and simple speed control. Fan blades have high aerodynamic efficient backward curved design. EC motors reduce the energy consumption and increase the energy efficiency of the unit. With EC Fans, maintenance costs are reduced as the fans are directly connected to the motors; the belt and pulley problems are eliminated.

Heat recovery exchanger (Aluminum)

PA - H / V energy recovery ventilation units have **aluminum** counterflow, high efficient plate heat recovery exchangers. Plate heat recovery exchangers have plates that are produced improved surface areas to provide high efficient and leakage free design. With the optimization of exchanger heat transfer is increased and pressure drop is decreased. Heat recovery exchanger has Eurovent certification.

Casing & insulation

The unit's casing is made up of double skinned high corrosion resistive 200 gr/m² galvanize coated steel. 50 mm thickness and 70 kg/m³ density of rockwool insulation between the walls is used for thermal and sound insulation. The case of unit is painted by electrostatic powdered paint. The unit is constructed in sections to ease transportation, mounting and commissioning.

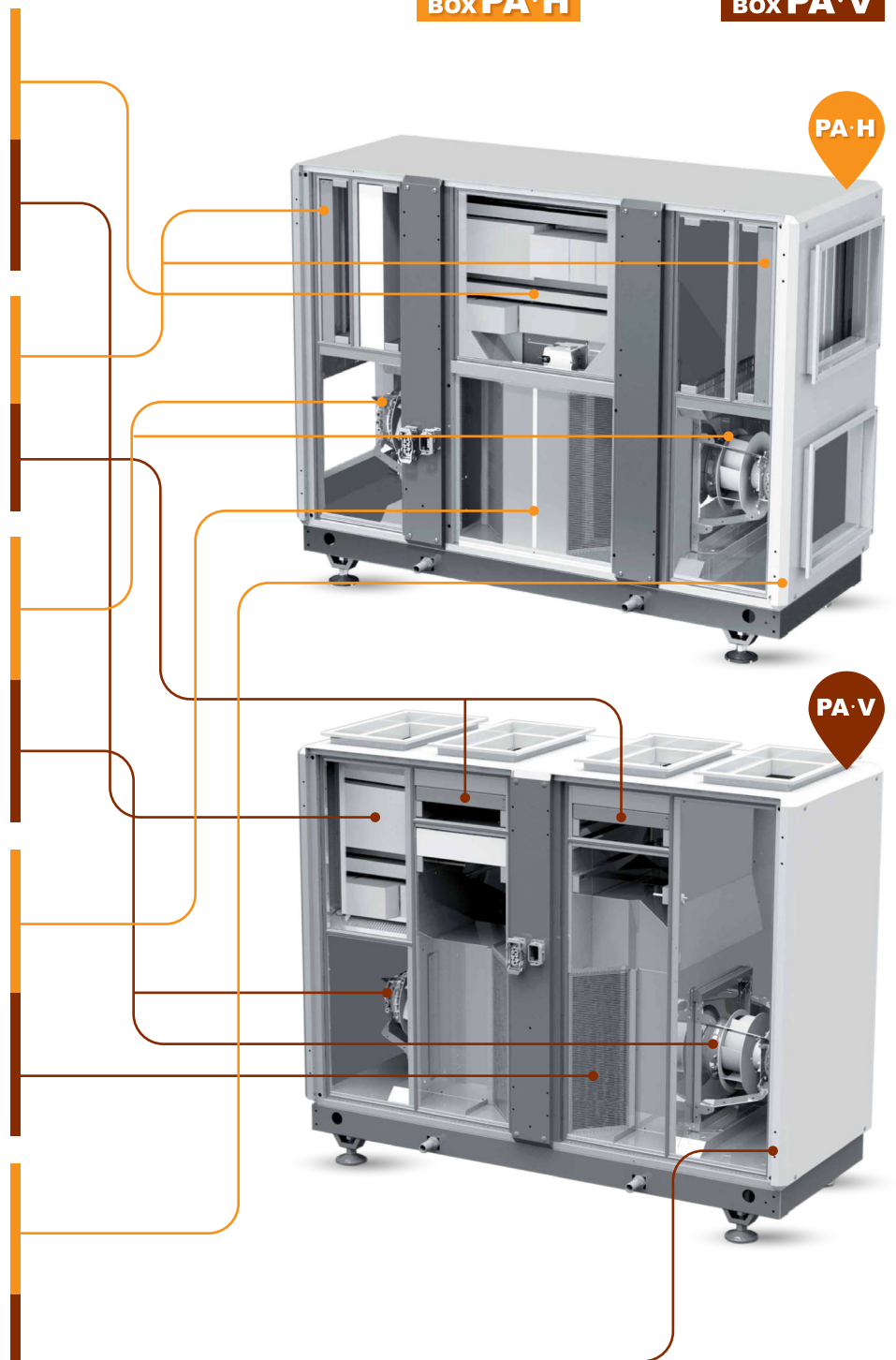

PA·H

PA·V

Performance data

ENERGY BOX PA - H / V 2.000

Performance curves

ENERGY BOX PA - H / V 3.000

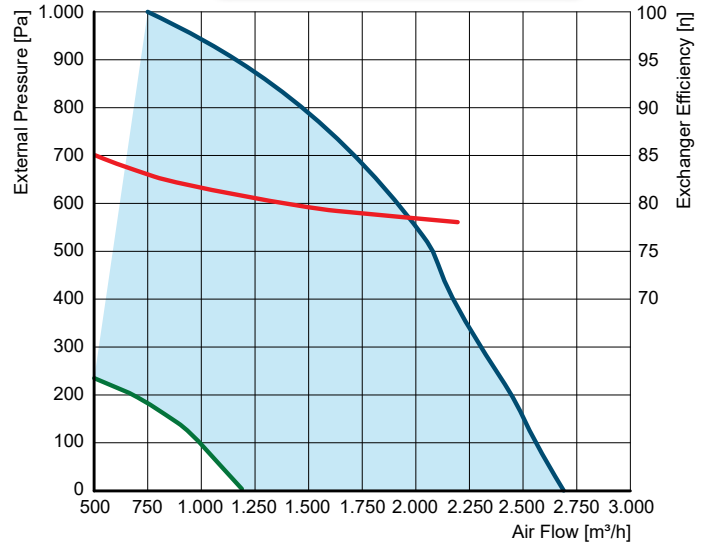
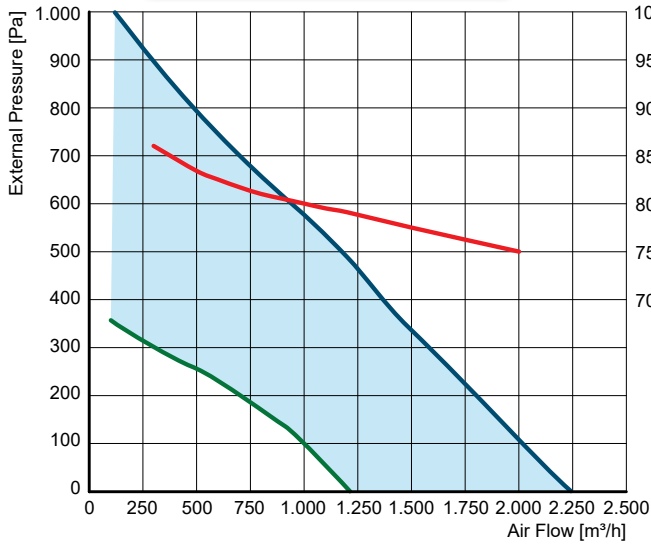

ENERGY BOX PA - H / V 4.000

Performance curves

ENERGY BOX PA - H / V 5.000

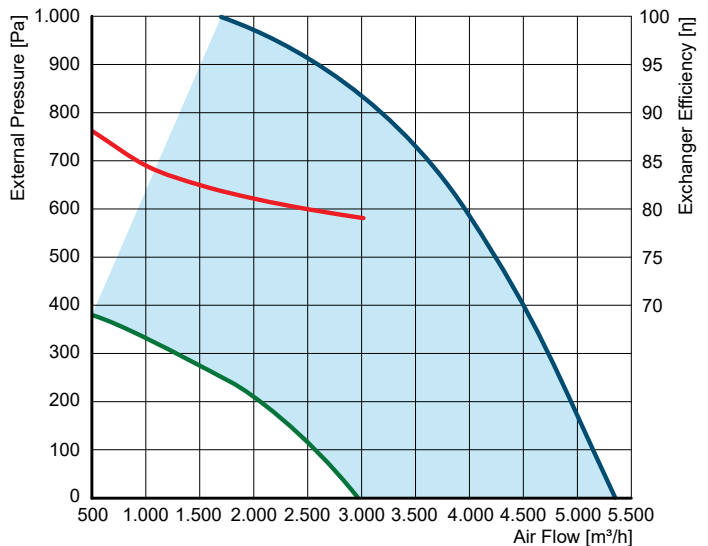
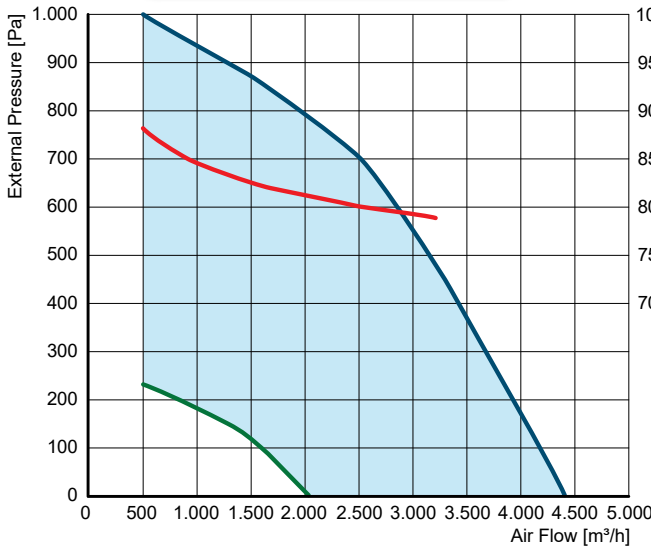

ENERGY BOX PA - H / V 7.000

Performance curves

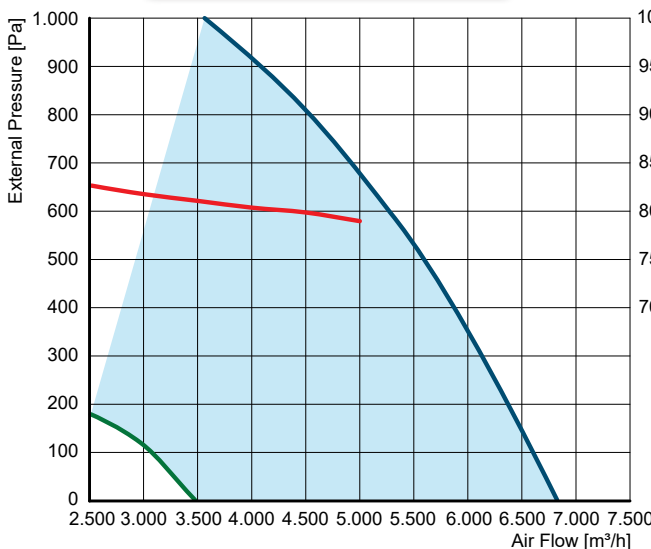

Note : Efficiency values are calculated according to EN 308 standard.

Technical specifications & unit dimensions

		PA - H / V 2.000	PA - H / V 3.000	PA - H / V 4.000	PA - H / V 5.000	PA - H / V 7.000
Thermal efficiency of heat recovery ¹	%	78	78	79	78	79
Nominal flow rate	m ³ /h	1.500	2.000	3.000	3.500	4.500
Maximum flow rate	m ³ /h	2.240	2.690	4.410	5.350	6.700
Effective electric power input	W	723	1.023	1.344	1.570	2.245
SFP int ¹	W(m ³ /s)	960,5	1.075,7	916,1	930,6	1.891,4
Face velocity at design flow rate	m/s	1,5	1,5	1,6	1,9	2,3
Nominal external pressure ($\Delta P_{s,ext}$) ¹	Pa	200				
Internal pressure drop of ventilation components ($\Delta P_{s,int}$)	Pa	238	271	253	262	197
Static efficiency of fans used in accordance with Regulation (EU) No. 327/2001	Pa	51,5	52	57,3	58,4	44,9
Declared maximum external leakage rate	%	Less than 3%				

¹ Measured at balanced flow, EN 308.

Front view

Side view

Top view

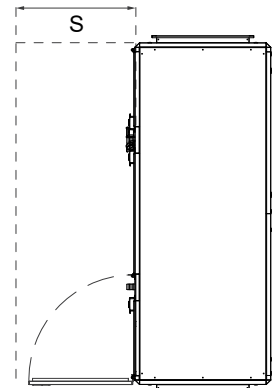
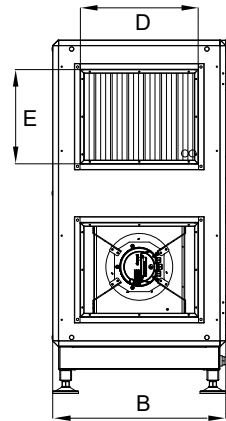
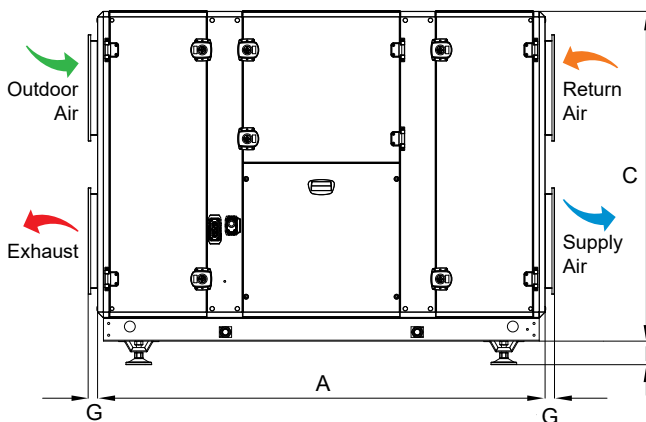

A clear space must be provided in front of the unit for service.

	PA - H 2.000	PA - H 3.000	PA - H 4.000	PA - H 5.000	PA - H 7.000
A	1.900	1.900	2.150	2.150	2.150
B	735	735	895	895	895
C	1.240	1.400	1.645	1.645	1.745
D x E	500 x 400	500 x 400	600 x 500	600 x 500	600 x 600
F	100	100	100	100	100
G	40	40	40	40	40
Weight [Kg]	275	305	420	425	485
S	800	800	900	900	900

"S" values indicate the size of the service area.
All measurement values are mm.

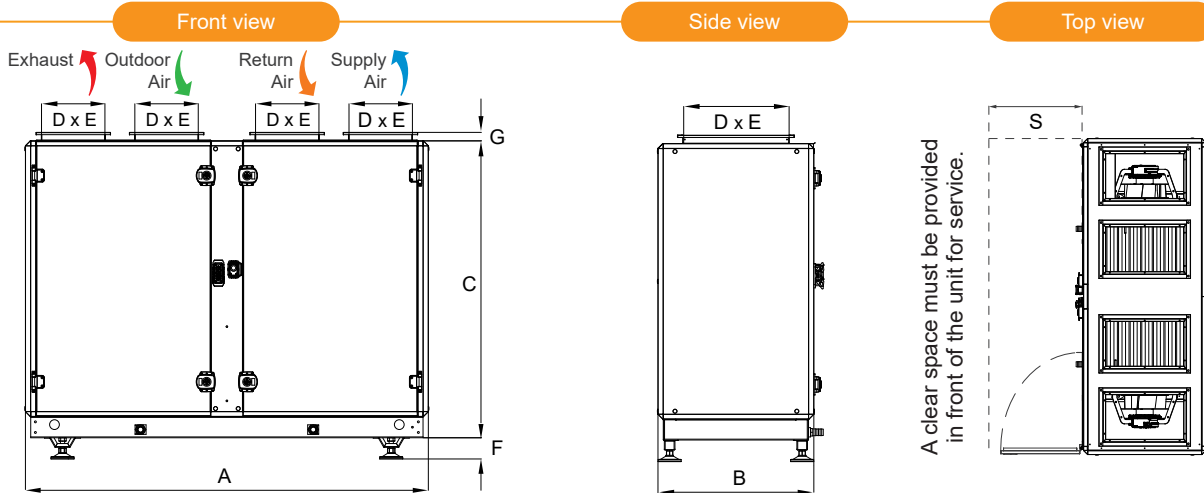

	PA - V 2.000	PA - V 3.000	PA - V 4.000	PA - V 5.000	PA - V 7.000
A	1.900	1.900	2.150	2.150	2.150
B	735	735	895	895	895
C	1.240	1.400	1.645	1.645	1.745
D x E	500 x 300	500 x 300	700 x 400	700 x 400	700 x 400
F	100	100	100	100	100
G	40	40	40	40	40
Weight [Kg]	275	305	420	425	485
S	900	900	1.000	1.000	1.000





"S" values indicate the size of the service area. / All measurement values are mm.

Control system

Automation Options		Control Cards				
Standard	Optional	Standard-Pro	Alternative 1	Alternative 2		
				Type 1	Type 1	Type 1
OA Temperature Sensor		☑	☑	☑	☑	☑
RA Temperature Sensor		☑	☑	☑	☑	☑
SA Fan Control		☑	☑	☑	☑	☑
RA Fan Control		☑	☑	☑	☑	☑
By-Pass Damper		☑	☑	☑	☑	☑
SA Temperature Sensor		☑	☑	☑	☑	☑
Modbus RTU		☑	☑	☑	☑	☑
Filter Contamination Info (DPS)		☑	☑	☑	☑	☑
Weekly Timer		☑	☑	☑	☑	☑
	On / Off Damper Control	☑	☑	☑	☑	☑
	Proportional Damper Control	☒	☑	☑	☑	☑
	Airflow Control		☑		☑	
	Humidity Control	⊖	☑	⊖	☑	⊖
	CO ₂ Control		☑		☑	
	On / Off Heating Coil	☑	☑	☑	☑	☑
	Proportional Heating Coil	☒	☑	☑	☑	☑
	On / Off Cooling Coil	☑	☑	☑	☑	☑
	Proportional Cooling Coil	☒	☑	☑	☑	☑
	Electrical Pre-Heater	☑	☑	☑	☑	☑
	Electrical After-Heater	☑	☑	☑	☑	☑
	BacNET MSTP	☒	☑	☑	☑	☑
	Web Browser (TCP/IP)	☒	☑	☒	☑	☒

⊖ Only one of them the defined functions is selectable for this control card.



Control Panel		Control Cards				
Panel Type	Panel Descriptions	Standard-Pro	Alternative 1	Alternative 2		
				Type 1	Type 2	Type 3
	Standard-Pro Wall-mounted type, Max : 50 m communication ability.	✓	✗	✗	✗	✗
	Alternative-1 Wall-mounted type hand panel, IP 30 protection class, Max : 100 m communication ability.	✗	✓	✗	✗	✗
	Alternative-2.1 Wall-mounted type room panel, IP 30 protection class, Max : 700 m communication ability.	✗	✗	✗	✗	✓
	Alternative-2.2 Hand Panel 1: Wall-mounted type, IP 65 protection class (front side of panel) Max : 50 m communication ability. Hand Panel 2: Magnet type, IP 65 protection class (whole panel) Max : 50 m communication ability.	✗	✗	✓	✓	✓
	Alternative-2.3 Magnet type, IP 31 protection class, Max : 700 m communication ability.	✗	✗	✓	✓	✓

Selection of electrical cable cross-section

Unit model	Voltage [V]	Power [kW]	Current [A]	Fuse [A]	Cable cross-section [mm ²] for 50 M & PF=0,8
PA - H / V 2.000	230	0,90	5	2 x 6	1,5
3.000	230	1,50	9	2 x 10	1,5
4.000	400	2,28	5	3 x 6	1,5
5.000	400	3,40	7	3 x 10	1,5
7.000	400	5,68	11	3 x 16	1,5

Cable cross-section formulas

Suitable for units with 400V supply voltage.

$$I_{\text{current}} = \frac{P}{\sqrt{3} \times U \times \text{CosQ}}$$

$$I_{\text{cable}} > I_{\text{current}}$$

$$\%e = \frac{100 \times P \times L}{k \times S \times U^2} \quad S = \frac{100 \times P \times L}{k \times \%e \times U^2}$$

$$\%e = \%3$$

$$I_{\text{cable}} > I_{\text{fuse}} \geq I_{\text{current}}$$

Cable Cross-section S = Max (S1, S2, S3, 1,5 mm²)

P : Power / I : Current / U : Voltage / S : Conductor cross-section / k : Conductor coefficient / L : Conductor length / %e : The voltage drop

Example of cable cross-section calculation

P : 5,68 kW / CosQ : 0,8 / U : 400V // k : 56 m/Ω / L : 50 m / %e : %3

$I_{\text{current}} = \frac{5.680 \text{ W}}{\sqrt{3} \times 400 \times 0,8} = 10,25 \text{ A}$ <p>The cable will be used, is selected from the cable cross-section table so that the equivalent ampere value in the table should be higher than calculated "I_{current}" value.</p> <p>S1 = 1,5 mm²</p>	$S = \frac{100 \times 5.680 \times 50}{56 \times 3 \times 400^2}$ <p>S2 ≥ 1 mm² S2 = 1 mm²</p>	$I_{\text{cable}} > I_{\text{fuse}} \geq I_{\text{current}}$ $I_{\text{cable}} > 16 \text{ A} \geq 10,25 \text{ A}$ <p>"I_{fuse}", which will be higher than "I_{current}", is selected. The cable will be used, is selected from the cable cross-section table so that the equivalent ampere value in the table should be higher than selected "I_{fuse}" value.</p> <p>I_{cable} = 24A S3 = 1,5 mm² S = Max (1,5, 1,5, 1,5, 1,5) S = 1,5 mm²</p>
---	--	--

Cable cross-section formulas

Suitable for units with 230V supply voltage.

$$I_{\text{current}} = \frac{P}{U \times \text{CosQ}}$$

$$I_{\text{cable}} > I_{\text{current}}$$

$$\%e = \frac{100 \times P \times L}{k \times S \times U^2} \quad S = \frac{100 \times P \times L}{k \times \%e \times U^2}$$

$$\%e = \%3$$

$$I_{\text{cable}} > I_{\text{fuse}} \geq I_{\text{current}}$$

$$\text{Cable Cross-section } S = \text{Max} (S1, S2, S3, 1,5 \text{ mm}^2)$$

P : Power / I : Current / U : Voltage / S : Conductor cross-section / k : Conductor coefficient / L : Conductor length / %e : The voltage drop

Example of cable cross-section calculation

P : 1,5 kW / CosQ : 0,8 / U : 230V / / k : 56 m/Ω / L : 50 m / %e : %3

$$I_{\text{current}} = \frac{1.500 \text{ W}}{230 \times 0,8} = 8,15 \text{ A}$$

The cable will be used, is selected from the cable cross-section table so that the equivalent ampere value in the table should be higher than calculated "I_{current}" value.

$$S1 = 1,5 \text{ mm}^2$$

$$S = \frac{100 \times 1.500 \times 50}{56 \times 3 \times 230^2} = 0,84 \text{ mm}^2$$

$$S2 \geq 1 \text{ mm}^2$$

$$S2 = 1 \text{ mm}^2$$

$$I_{\text{cable}} > I_{\text{fuse}} \geq I_{\text{current}}$$

$$I_{\text{cable}} > 10 \text{ A} \geq 8,15 \text{ A}$$

"I_{fuse}", which will be higher than "I_{current}", is selected.

The cable will be used, is selected from the cable cross-section table so that the equivalent ampere value in the table should be higher than selected "I_{fuse}" value.

$$I_{\text{cable}} = 24\text{A} \quad S3 = 1,5 \text{ mm}^2$$

$$S = \text{Max} (1,5, 1, 1,5, 1,5) \quad S = 1,5 \text{ mm}^2$$

Accessories

Duct type electric heaters



Electric heaters are optionally supplied in cold climates for supply air and in extreme climates for both supply and outdoor air sides against freezing. Electric heaters are manufactured according to circular or rectangular duct systems. Standard types are produced of stainless steel heating elements and galvanized metal casing. Stainless steel casing is also available. Electric heaters are equipped with two circuit cutting thermostats. Factory setting for the automatically operating one is 70 °C and for the manual operating 110 °C.

Electric heaters capacity can be controlled up to 2 or 3 steps with control system of unit according to the set temperature from the room control panel and room (or supply air) temperature. Speed controls shall not be used with Electric heater installations. Eneko electric heaters are connected in Delta connection in standard models

Heating capacity calculation : $Q = 0,33 \times V \times (T_2 - T_1)$ | Q : Heating capacity (W) | T₁ : Air temperature before the heater (°C)
V : Air flow through electric heater (m³/h) | T₂ : Air temperature after the heater (°C)

ELECTRICAL HEATER CAPACITY

Unit model PA - H / V	Capacity (pre-heater) [kW] (Outdoor air between 0 °C and -5 °C)*	Capacity (pre-heater) [kW] (Outdoor air between -5 °C and -15 °C)*	Capacity (after-heater) [kW] (Heating the supply air to 25 °C)*
2.000	5	12	5 - 6
3.000	5	12	5 - 8
4.000	6	20	6 - 12
5.000	8	25	8 - 15
7.000	12	34	12 - 20

* All pre-heaters and after-heaters are duct type.



Duct type HEATING coil



Duct type heating / cooling coils are assembled in cabin as suitable to mount inside duct and have standard capacity. Coils consist of copper tubes and aluminum fins. Inlets and outlets of cabin are suitable for circular duct connections as in heat recovery ventilation units. Additionally, cooling coils have drain pan and extra insulation to prevent condensation of cabin. Both heating and cooling coils can be controlled separately as on / off via unit automation system.

All values are calculated according to EN 308 standard.

		90 °C / 70 °C WATER				80 °C / 60 °C WATER			
Unit model	Air flow [m³/h]	Air side pressure drop [Pa]	Capacity [kW]	Fluid side pressure drop [kPa]	Supply air temp. [°C]	Air side pressure drop [Pa]	Capacity [kW]	Fluid side pressure drop [kPa]	Supply air temp. [°C]
PA - H / V									
2.000	1.100	49	12,4	1,50	55,0	48	9,80	1,0	47,8
	1.710	28	13,7	1,80	44,0	27	10,9	1,2	39,0
3.000	1.700	9	11,0	3,60	39,4	9	8,90	2,5	35,7
	2.430	17	13,5	5,20	36,6	17	10,9	3,6	33,4
4.000	2.200	6	14,8	2,50	41,9	6	11,8	1,7	37,8
	3.740	15	20,8	4,80	36,7	15	16,7	3,2	33,4
5.000	3.250	9	22,1	8,70	40,2	8	18,0	6,0	36,5
	5.200	19	28,9	10,5	36,5	19	23,5	9,9	33,4
7.000	3.900	73	44,1	7,50	55,4	72	35,8	5,1	49,0
	6.900	190	65,2	11,0	48,1	188	53,0	7,5	42,9

		70 °C / 50 °C WATER				60 °C / 40 °C WATER			
Unit model	Air flow [m³/h]	Air side pressure drop [Pa]	Capacity [kW]	Fluid side pressure drop [kPa]	Supply air temp. [°C]	Air side pressure drop [Pa]	Capacity [kW]	Fluid side pressure drop [kPa]	Supply air temp. [°C]
PA - H / V									
2.000	1.100	48	6,90	0,5	40,2	47	2,9	0,1	29,2
	1.710	27	7,90	0,7	33,8	27	4,1	0,2	27,2
3.000	1.700	9	6,80	1,5	32,0	9	4,6	0,8	28,1
	2.430	16	8,30	2,2	30,2	16	5,6	1,1	26,9
4.000	2.200	6	8,70	1,0	33,7	6	5,4	0,4	29,1
	3.740	15	12,6	1,9	30,0	15	8,2	0,9	26,6
5.000	3.250	8	13,9	3,8	32,7	8	9,7	2,0	28,8
	5.200	19	18,1	6,2	30,3	18	12,6	3,2	27,1
7.000	3.900	71	27,3	3,1	42,4	70	18,5	3,2	35,6
	6.900	186	40,7	6,6	37,5	184	28	3,3	32,0

Note:
Calculated values are derived from different coils which can be fitted into same coilbox for each model in order to reach desired conditions.



Duct type COOLING coil

		7 °C / 12 °C WATER				6 °C / 10 °C WATER			
Unit model	Air flow [m ³ /h]	Air side pressure drop [Pa]	Capacity [kW]	Fluid side pressure drop [kPa]	Supply air temp. [°C]	Air side pressure drop [Pa]	Capacity [kW]	Fluid side pressure drop [kPa]	Supply air temp. [°C]
PA - H / V									
2.000	1.100	28	4,40	4,10	14,6	33	5,80	6,40	12,9
	1.710	59	6,40	8,40	15,7	67	7,90	11,2	14,5
3.000	1.700	35	6,80	4,90	14,5	40	8,70	11,3	13,1
	2.430	65	9,20	8,30	15,7	74	11,3	14,6	14,5
4.000	2.200	25	9,60	7,30	13,8	28	12,6	13,3	12,0
	3.740	61	14,9	12,1	15,3	69	18,6	27,3	14,0
5.000	3.250	34	14,0	9,70	14,2	39	18,0	23,2	12,5
	5.200	76	20,2	19,0	15,7	87	25,2	33,3	14,4
7.000	3.900	25	15,1	4,80	14,4	28	19,7	5,90	12,8
	6.900	66	24,7	5,90	16,0	75	30,5	13,2	14,9

Duct type COOLING coil

		R407C, 5 °C / 54 °C			
Unit model	Air flow [m ³ /h]	Air side pressure drop [Pa]	Capacity [kW]	Fluid side pressure drop [kPa]	Supply air temperature [°C]
PA - H / V					
2.000	1.100	36	6,50	4,70	13,0
	1.710	76	8,50	7,90	15,2
3.000	1.700	45	9,50	8,10	13,5
	2.430	83	12,0	12,8	15,2
4.000	2.200	31	13,7	13,1	12,2
	3.740	77	19,6	23,6	14,7
5.000	3.250	43	19,3	23,7	12,9
	5.200	96	26,3	43,4	15,2
7.000	3.900	32	22,8	25,8	12,8
	6.900	86	32,9	52,5	15,6

		R410A, 5 °C / 54 °C			
Unit model	Air flow [m ³ /h]	Air side pressure drop [Pa]	Capacity [kW]	Fluid side pressure drop [kPa]	Supply air temperature [°C]
PA - H / V					
2.000	1.100	29	5,30	2,40	13,1
	1.710	59	6,90	4,10	14,6
3.000	1.700	35	7,90	4,80	13,6
	2.430	65	9,90	7,40	14,8
4.000	2.200	25	11,3	8,60	12,8
	3.740	59	15,8	16,8	14,5
5.000	3.250	33	15,7	16,2	13,3
	5.200	75	20,9	28,7	14,9
7.000	3.900	26	19,2	20,6	13,1
	6.900	67	27,4	41,7	15,0



ISO 9001:2015



ISO 14001:2015

Management System
ISO 14001:2015
Valid until:
2024-05-24



www.tuv.com
ID: 9108660718

AIR HANDLING UNITS



HEAT EXCHANGERS



FAN COIL UNITS



FANS & FAN SECTIONS



FIRE DAMPERS



AIR OUTLETS



STEAM HUMIDIFIERS - DEHUMIDIFIERS



CENTRAL VACUUM SYSTEMS



TUBO
THINK CLEAN

STAINLESS STEEL CHIMNEYS



AIR FILTERS



AIR CURTAINS



EVAPORATIVE COOLING



Main Office ATHENS

📍 Paparrigopoulou 10 & Lagada,
12132, Peristeri, Athens
211 - 705.55.00
✉ sales@airtechnic.gr

Factory - THIVA

📍 4th km Thiva - Chalkida Hwy,
32200, Thiva
22620 - 89.006
✉ factory@airtechnic.gr

Factory - THESSALONIKI

📍 End of Meandrou Str.,
57013, Oraiokastro, Thessaloniki
2311 - 82.40.00
✉ thessaloniki@airtechnic.gr