

INVISAIR DX-MD | Heat Pump Energy Saving Air Curtains For MIDEA Outdoor Units (1:1)

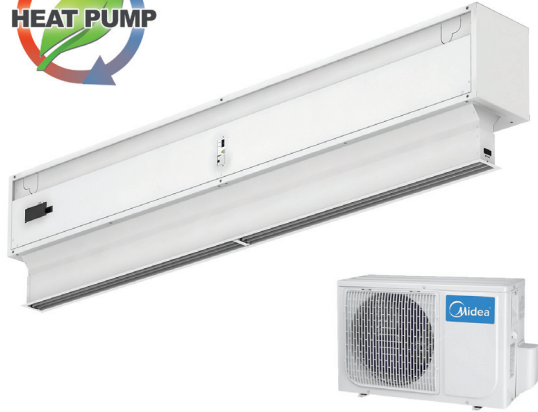

Characteristics



- Energy saving heat pump air curtains: Up to 70% reduction in costs and CO₂ emissions (heating mode).
- Specially designed for applications where the body of the air curtain is to be installed inside a column or bulkhead for architectural reasons. It can be vertically or horizontally mounted.
- Self-supporting casing construction made of galvanized steel plate, finished in structural epoxy-polyester painting white colour RAL9016 as standard. Other colours or stainless steel are available on request.
- The air flow of Invisair follows a straight line from the air inlet grille to the discharge. Inlet area inside a bulkhead or column should be designed with suitable grille provided by others.
- Anodized aluminium outlet vanes, airfoil shaped, adjustable from 0 to 15° each side.
- EC Double-inlet centrifugal fans driven by an external rotor motor and low noise level, with very low consumption efficiency fans.
- Includes direct expansion coil with sensors. Optional condensate water pump.
- CS-5DX-NE Plug&Play control with 5 speeds and telephone cable 7m included.
- Requires DX Interface KIT adapted for air curtain and programmable control, please consult.
- Ready to connect to MIDEA Inverter outdoor heat pump unit (R410A) with expansion valve, not included, the customer should purchase it.

Specifications

Model	Airflow m ³ /h	Outdoor Unit (*)		Power Fans	Current Fans	Noise Level	Weight kg
		230Vx1	400Vx3	230V-50Hz kW	230V-50Hz A	(5 m) dB(A)	
IECG 1500 DX15-MD	2920	MOE30U-48HFN1-QRD0	MOE30U-48HFN1-RRD0	0,284	2,48	62	69
IECG 2000 DX18-MD	4380	-	MOE30U-55HFN1-RRD0	0,426	3,72	63	89
IECG 2000 DX22/2-MD	4380	2x MOD30U-36HFN1-QRD0	2x MOD30U-36HFN1-RRD0	0,426	3,72	63	89
IECG 2500 DX29/2-MD	5110	2x MOE30U-48HFN1-QRD0	2x MOE30U-48HFN1-RRD0	0,497	4,34	64	94

22/2 Double circuit and two outdoor units of 11kW. 29/2 Double circuit and two outdoor units of 16kW.

(*) Includes direct expansion valve.

MIDEA Inverter Outdoor Units	Heating Capacity	Heating Power	SCOP or COP (*)	Cooling Capacity	Cooling Power	SEER or EER (*)	Power Supply	Pipes Gas Liquid	Pipes Maximum Length	Pipes Maximum Height
	kW	kW	W/W	kW	kW	W/W		inch	m	m
MOD30U-36HFN1-QRD0	11,1	2,9	3,82	10,5	3,95	2,65	230Vx1	5/8 3/8	65	30
MOD30U-36HFN1-RRD0	11,1	2,9	3,82	10,5	3,95	2,65	400Vx3	5/8 3/8	65	30
MOE30U-48HFN1-QRD0	16,1	4,4	3,65	14,1	5,10	2,76	230Vx1	5/8 3/8	65	30
MOE30U-48HFN1-RRD0	16,1	4,4	3,65	14,1	5,10	2,76	400Vx3	5/8 3/8	65	30
MOE30U-55HFN1-RRD0	17,6	5,5	3,20	16,1	6,30	2,55	400Vx3	5/8 3/8	65	30

Energy efficiency: SCOP/SEER seasonal ≤12kW, COP/EER >12kW.

Outdoor unit capacities depending on standard conditions: heating 20°CDB indoor / 7°CDB and 6°CWB outdoor, cooling 27°CDB and 19°CWB indoor / 35°CDB outdoor.

When adverse weather conditions, the outdoor unit capacity can decrease. It is recommendable to oversize the units.

INVISAIR DX-MD | Heat Pump Energy Saving Air Curtains For MIDEA Outdoor Units (1:1)



Layouts and dimensions

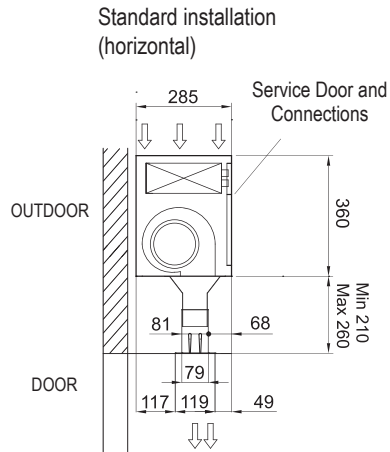
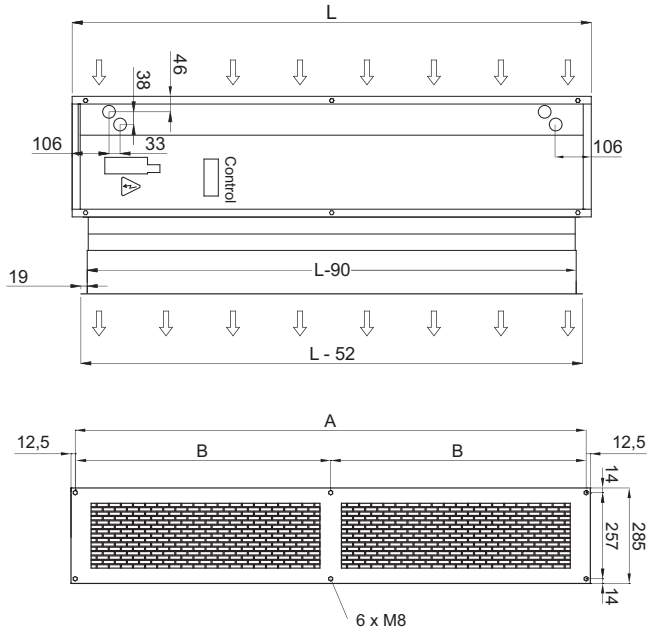

OPTIONAL
Connections with lateral entrance

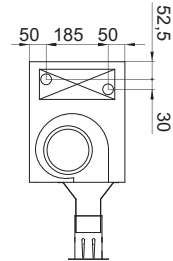

Invisair	L	A	B
1500	1550	1525	762,5
2000	2055	2030	1015
2500	2555	2530	1265

Installation example

