

## DAM DX-MD | Heat Pump Energy Saving Air Curtains For MIDEA Outdoor Units (1:1)



### Characteristics



- Energy saving heat pump air curtains: Up to 70% reduction in costs and CO<sub>2</sub> emissions (heating mode).
- Self-supporting casing construction made of galvanized steel plate, finished in structural epoxy-polyester painting white colour RAL9016 as standard. Other colours or stainless steel are available on request.
- Front panel with option to customize and the possibility of including personalized logos, signs, graphic designs, images, etc.
- The inlet areas are located behind the front panel. They do not need maintenance.
- Anodized aluminium outlet vanes, airfoil shaped, adjustable from 0 to 15° each side.
- EC Double-inlet centrifugal fans driven by an external rotor motor and low noise level, with very low consumption efficiency fans.
- Includes direct expansion coil with sensors. Optional condensate water pump.
- CS-5DX-NE Plug&Play control with 5 speeds and telephone cable 7m included.
- Requires DX Interface KIT adapted for air curtain and programmable control, please consult.
- Ready to connect to MIDEA Inverter outdoor heat pump unit (R410A) with expansion valve, not included, the customer should purchase it.

### Specifications

Model	Airflow m <sup>3</sup> /h	Outdoor Unit (*)		Power Fans	Current Fans	Noise Level	Weight kg
		230Vx1	400Vx3	230V-50Hz kW	230V-50Hz A	(5 m) dB(A)	
DAM ECM 1000 DX7-MD	1640	MOCA30U-24HFN1-QRD0	-	0,142	1,24	56	43
DAM ECM 1500 DX11-MD	2460	MOD30U-36HFN1-QRD0	MOD30U-36HFN1-RRD0	0,213	1,86	57	64
DAM ECM 2000 DX16-MD	3280	MOE30U-48HFN1-QRD0	MOE30U-48HFN1-RRD0	0,284	2,48	58	81
DAM ECG 1000 DX10-MD	2190	MOD30U-36HFN1-QRD0	MOD30U-36HFN1-RRD0	0,213	1,86	61	48
DAM ECG 1500 DX15-MD	2920	MOE30U-48HFN1-QRD0	MOE30U-48HFN1-RRD0	0,284	2,48	62	70
DAM ECG 2000 DX18-MD	4380	-	MOE30U-55HFN1-RRD0	0,426	3,72	63	91
DAM ECG 2000 DX22/2-MD	4380	2x MOD30U-36HFN1-QRD0	2x MOD30U-36HFN1-RRD0	0,426	3,72	63	91
DAM ECG 2500 DX29/2-MD	5110	2x MOE30U-48HFN1-QRD0	2x MOE30U-48HFN1-RRD0	0,497	4,34	64	97
DAM ECG 3000 DX32/2-MD	5840	2x MOE30U-48HFN1-QRD0	2x MOE30U-48HFN1-RRD0	0,568	5,96	65	111

22/2 Double circuit and two outdoor units of 11kW. 29/2 and 32/2 Double circuit and two outdoor units of 16kW.

(\*) Includes direct expansion valve.

MIDEA Inverter Outdoor Units	Heating Capacity		SCOP or COP (*)	Cooling Capacity		SEER or EER (*)	Power Supply	Pipes		Pipes Maximum Length	Pipes Maximum Height
	kW	kW		kW	kW			Gas	Liquid		
			W/W			W/W		inch	m	m	
MOCA30U-24HFN1-QRD0	7,6	1,8	4,22	7,0	2,13	3,28	230Vx1	5/8	3/8	50	25
MOD30U-36HFN1-QRD0	11,1	2,9	3,82	10,5	3,95	2,65	230Vx1	5/8	3/8	65	30
MOD30U-36HFN1-RRD0	11,1	2,9	3,82	10,5	3,95	2,65	400Vx3	5/8	3/8	65	30
MOE30U-48HFN1-QRD0	16,1	4,4	3,65	14,1	5,10	2,76	230Vx1	5/8	3/8	65	30
MOE30U-48HFN1-RRD0	16,1	4,4	3,65	14,1	5,10	2,76	400Vx3	5/8	3/8	65	30
MOE30U-55HFN1-RRD0	17,6	5,5	3,20	16,1	6,30	2,55	400Vx3	5/8	3/8	65	30

Energy efficiency: SCOP/SEER seasonal ≤12kW, COP/EER >12kW.

Outdoor unit capacities depending on standard conditions: heating 20°CDB indoor / 7°CDB and 6°CWB outdoor, cooling 27°CDB and 19°CWB indoor / 35°CDB outdoor.

When adverse weather conditions, the outdoor unit capacity can decrease. It is recommendable to oversize the units.

## DAM DX-MD | Heat Pump Energy Saving Air Curtains For MIDEA Outdoor Units (1:1)



### Dimensions

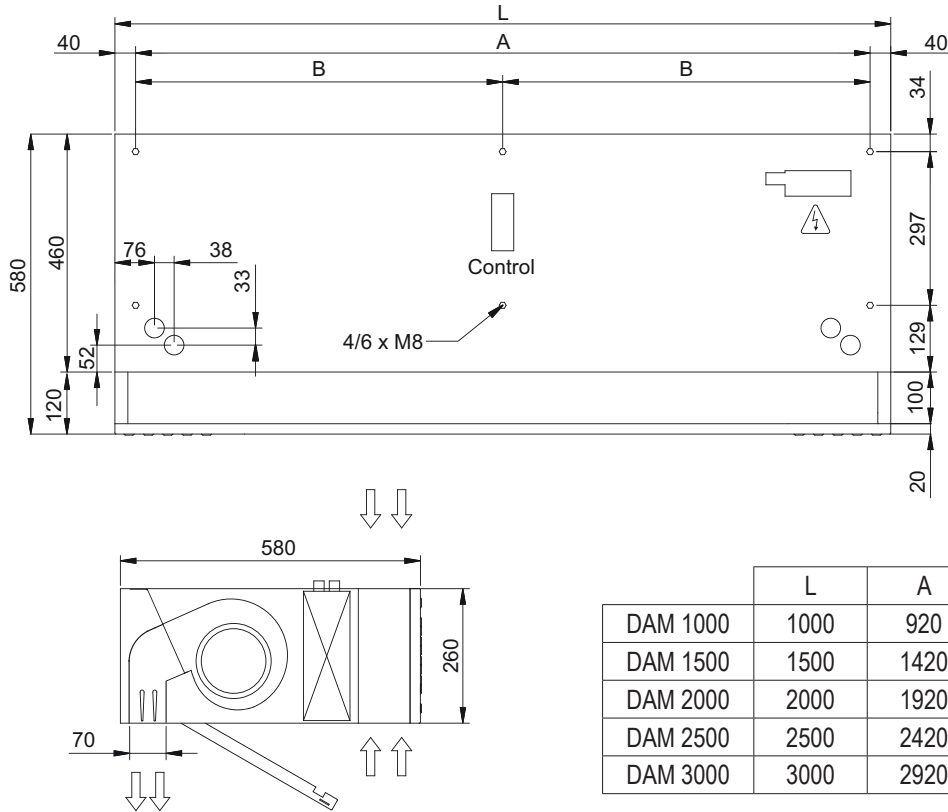

### Finishes and details

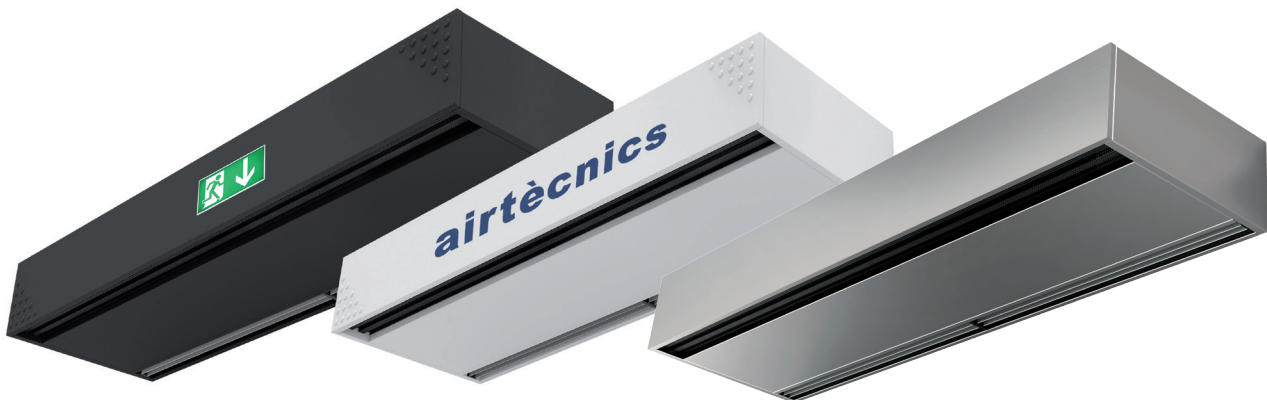

- Painted any RAL colour
- Available in stainless steel AISI 304 (brushed)
- Customizable with logos, signs, vinyls, etc.