

INVISAIR DX-HI | Heat Pump Energy Saving Air Curtains For HITACHI Outdoor Units (1:1)



Characteristics



- Energy saving heat pump air curtains: Up to 70% reduction in costs and CO₂ emissions (heating mode).
- Specially designed for applications where the body of the air curtain is to be installed inside a column or bulkhead for architectural reasons. It can be vertically or horizontally mounted.
- Self-supporting casing construction made of galvanized steel plate, finished in structural epoxy-polyester painting white colour RAL9016 as standard. Other colours or stainless steel are available on request.
- The air flow of Invisair follows a straight line from the air inlet grille to the discharge. Inlet area inside a bulkhead or column should be designed with suitable grille provided by others.
- Anodized aluminium outlet vanes, airfoil shaped, adjustable from 0 to 15° each side.
- EC Double-inlet centrifugal fans driven by an external rotor motor and low noise level, with very low consumption efficient fans.
- Includes direct expansion coil with sensors. Optional condensate water pump.
- CS-5DX-NE Plug&Play control with 5 speeds and telephone cable 7m included.
- Requires HITACHI DX Interface KIT adapted for air curtain with expansion valve and programmable control, please consult.
- Ready to connect to HITACHI Inverter outdoor heat pump unit (R410A), not included, the customer should purchase it.

Specifications

Model	Airflow m ³ /h	Outdoor Unit 230Vx1	Outdoor Unit 400Vx3	Hitachi Kit Interface DX (*)	Power Fans 230V-50Hz kW	Current Fans 230V-50Hz A	Noise Level (5 m) dB(A)	Weight kg
IECG 1500 DX13-HI	2920	RAS-5HVNC1E	RAS-5HNC1E	EXV-5.0E2	0,284	2,48	62	69
IECG 1500 DX15-HI	2920	RAS-6HVNC1E	RAS-6HNC1E	EXV-6.0E2	0,284	2,48	62	69
IECG 2000 DX22-HI	4380	-	RAS-8HNCE	EXV-8.0E2	0,426	3,72	63	89
IECG 2500 DX22-HI	5110	-	RAS-8HNCE	EXV-8.0E2	0,497	4,34	64	94
IECG 2500 DX28-HI	5110	-	RAS-10HNCE	EXV-10.0E2	0,497	4,34	64	94

(*) Includes direct expansion valve.

HITACHI Utopia IVX Confort (*) Outdoor Units	Heating Capacity kW	Heating Power kW	SCOP or COP	Cooling Capacity kW	Cooling Power kW	SEER or EER	Power Supply	Pipes Gas Liquid inch	Pipes Maximum Length m	Pipes Maximum Height m
RAS-5HVNC1E	14,0	3,60	3,89	12,5	3,71	3,37	230Vx1	5/8 3/8	75	30
RAS-5HNC1E	14,0	3,60	3,89	12,5	3,71	3,37	400Vx3	5/8 3/8	75	30
RAS-6HVNC1E	16,0	4,29	3,73	14,0	4,29	3,26	230Vx1	5/8 3/8	75	30
RAS-6HNC1E	16,0	4,29	3,73	14,0	4,29	3,26	400Vx3	5/8 3/8	75	30
RAS-8HNCE	22,4	5,88	3,81	20,0	5,95	3,36	400Vx3	1 3/8	100	30
RAS-10HNCE	28,0	7,71	3,63	25,0	8,28	3,02	400Vx3	1 1/2	100	30

(*) Also compatible with outdoor units Utopia ES, VRF Centrifugal, Utopia IVX Premium.

Energy efficiency: SCOP/SEER seasonal ≤12kW, COP/EER >12kW.

Outdoor unit capacities depending on standard conditions: heating 20°CDB indoor / 7°CDB and 6°CWB outdoor, cooling 27°CDB and 19°CWB indoor / 35°CDB outdoor.

When adverse weather conditions, the outdoor unit capacity can decrease. It is recommendable to oversize the units.

INVISAIR VRF-HI | Heat Pump Energy Saving Air Curtains For HITACHI Outdoor Units (VRF)



Characteristics



- Energy saving heat pump air curtains: Up to 70% reduction in costs and CO₂ emissions (heating mode).
- Specially designed for applications where the body of the air curtain is to be installed inside a column or bulkhead for architectural reasons. It can be vertically or horizontally mounted.
- Self-supporting casing construction made of galvanized steel plate, finished in structural epoxy-polyester painting white colour RAL9016 as standard. Other colours or stainless steel are available on request.
- The air flow of Invisair follows a straight line from the air inlet grille to the to the discharge. Inlet area inside a bulkhead or column should be designed with suitable grille provided by others.
- Anodized aluminium outlet vanes, airfoil shaped, adjustable from 0 to 15° each side.
- EC Double-inlet centrifugal fans driven by an external rotor motor and low noise level, with very low consumption efficient fans.
- Includes direct expansion coil with sensors. Optional condensate water pump.
- CS-5DX-NE Plug&Play control with 5 speeds and telephone cable 7m included.
- Requires HITACHI VRF Interface KIT adapted for air curtain with expansion valve and programmable control, please consult.
- Ready to connect to HITACHI VRF outdoor heat pump unit (R410A), not included, the customer should purchase it.

Specifications

Model	Airflow m ³ /h	Hitachi Kit Interface VRF (*)	Power Fans 230V-50Hz kW	Current Fans 230V-50Hz A	Noise Level (5 m) dB(A)	Weight kg
IECG 1500 VRF13-HI	2920	EXV-5.0E2	0,284	2,48	62	69
IECG 1500 VRF15-HI	2920	EXV-6.0E2	0,284	2,48	62	69
IECG 2000 VRF20-HI	4380	EXV-8.0E2	0,426	3,72	63	89
IECG 2000 VRF24-HI	4380	EXV-8.0E2	0,426	3,72	63	89
IECG 2500 VRF25-HI	5110	EXV-8.0E2	0,497	4,34	64	94
IECG 2500 VRF29-HI	5110	EXV-10.0E2	0,497	4,34	64	94

(*) Includes direct expansion valve.

HITACHI VRF Outdoor Units

Utopia ES / Utopia IXV Confort

VRF Centrifugal

Utopia IXV Premium / Set Free Mini / Front Flow

Set Free



When adverse weather conditions, the outdoor unit capacity can decrease. It is recommendable to oversize the units.

INVISAIR DX/VRF-HI | Heat Pump Energy Saving Air Curtains For HITACHI Outdoor Units (1:1/VRF)



Layouts and dimensions

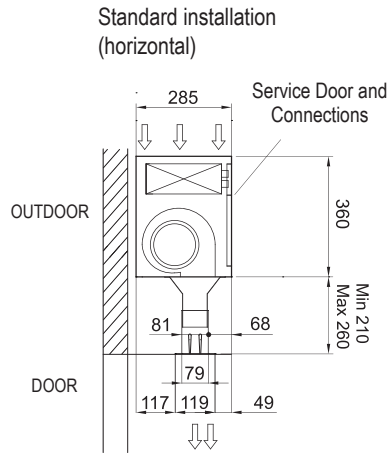
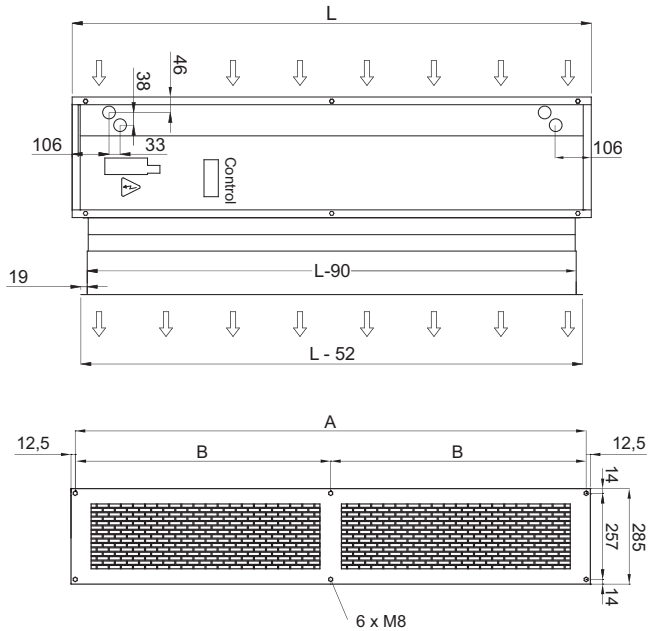

OPTIONAL
Connections with lateral entrance

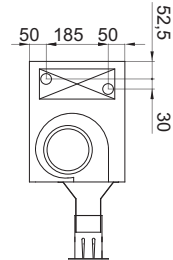

Invisair	L	A	B
1500	1550	1525	762,5
2000	2055	2030	1015
2500	2555	2530	1265

Installation example

