



BRCF

HORIZONTAL OUTLET ROOF FANS / Backward Curved

Fan Components and Material Properties

BRCF series vertical centrifugal roof type radial fans Body, mounting plate and models of BRCF 280-400 fan impellers made of galvanized sheet steel, models of BRCF 450-560 fan impellers made of aluminum sheet and models BRCF 630-800 made of electrostatic powder coated sheet steel It was. Asynchronous motor is used in all models. The motor is out of airflow. The device is capable of carrying air at max.120°C.

Fan Structure

The fan blades are aerodynamically curved and provide regular flow. The fans are composed of backward sloping and infrequently aligned fins with the insertion technique, while the fan wheels of the models BRCF 630-800 are manufactured from the necessity of high strength.

Benefits

BRCF roof fans provide a great advantage in applications with vertical shot feature, especially in conditions where horizontal air is not absorbed.

Thanks to the aerodynamic wing structure, they work quietly. Speed can be adjusted with speed control devices. Since the motor is out of airflow, it is resistant to high temperature. Due to its high temperature resistance, the hot oil vapor absorbed from the hoods ensures a long distance to the vertical.

Speed Control

Optional control devices can be provided. Speed control with frequency inverter can be done in 3 ~ phase products (see BSC-F accessory)

Usage Areas

It is used in cases where air is needed to evacuate horizontally in order to increase the air quality of indoor spaces. BRCF roof fans operate at low volume with asynchronous norm motor. It is used in the roofs of the places where the air is to be refreshed, the chimneys on the bathroom and wc roofs of the buildings and the ventilation and hood system applications.

Technical Drawing and Tables

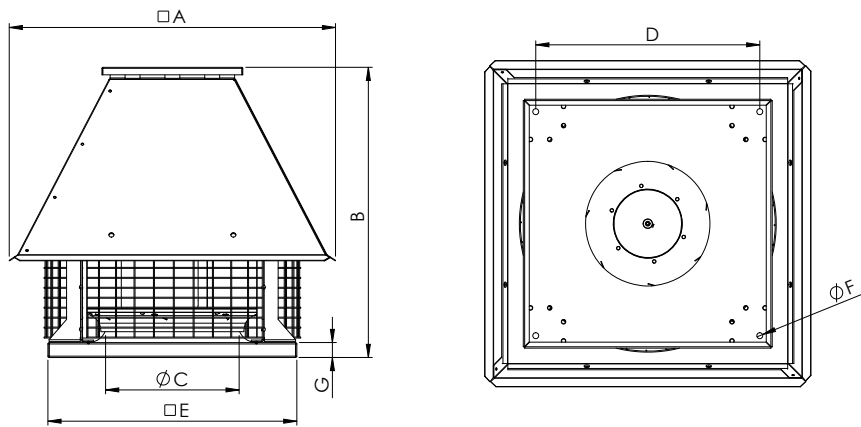

TYPE	A	B	C	D	E	F	G
BRCF 280	522	495	165	354	404	10	30
BRCF 315	595	555	198	404	454	10	30
BRCF 355	656	555	234	450	500	10	30
BRCF 400	656	585	268	450	500	12	30
BRCF 450	656	616	303	530	580	12	44
BRCF 500	766	660	342	590	640	12	44
BRCF 560	828	723	380	650	700	12	44
BRCF 630	997	922	445	660	730	12	54
BRCF 710	1095	991	500	710	780	12	54
BRCF 800	1205	1172	542	850	900	12	54

Dimensions are in (mm)

Accessories

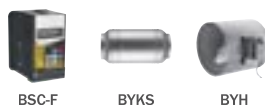

TYPE	VOLTAGE	FREQUENCY	POWER	CURRENT	CAPACITOR	SPEED	AIR FLOW	SOUND PRESSURE	INSULATION CLASS	PROTECTION CLASS	WEIGHT
	V	Hz	kW	(A)	(μ F)	r.p.m	m ³ /h	dB(A)	Ins.cl.	IP	kg
BRCF 280M	230	50	0,25	2,1	10	1390	1000	53-45	F	55	35
BRCF 315M	230	50	0,25	2,1	10	1380	1950	53-45	F	55	42
BRCF 355M	230	50	0,25	2,1	10	1380	2900	55-47	F	55	50
BRCF 400M	230	50	0,37	3,4	15	1390	4000	60-52	F	55	55
BRCF 450M	230	50	0,55	4,5	20	1365	5550	62-54	F	55	62
BRCF 500M	230	50	1,1	7,5	35	1410	8300	64-56	F	55	68
BRCF 560M	230	50	2,2	14,2	50	1420	10800	66-58	F	55	75
BRCF 280T	380	50	0,25	0,87	-	1380	1000	53-45	F	55	35
BRCF 315T	380	50	0,25	0,87	-	1380	1950	53-45	F	55	42
BRCF 355T	380	50	0,25	0,87	-	1380	2900	55-47	F	55	50
BRCF 400T	380	50	0,37	1,2	-	1390	4000	60-52	F	55	55
BRCF 450T	380	50	0,55	1,6	-	1365	5550	62-54	F	55	62
BRCF 500T	380	50	1,1	2,6	-	1410	8300	64-56	F	55	68
BRCF 560T	380	50	2,2	4,9	-	1420	10800	66-58	F	55	75
BRCF 630T	380	50	3	6,6	-	1000	13000	60-52	F	55	127
BRCF 710T	380	50	4	8,4	-	1000	15000	63-55	F	55	150
BRCF 800T	380	50	7,5	15,4	-	1000	17000	67-59	F	55	216

The sound level is measured at a distance of 4-10 m in open field condition.

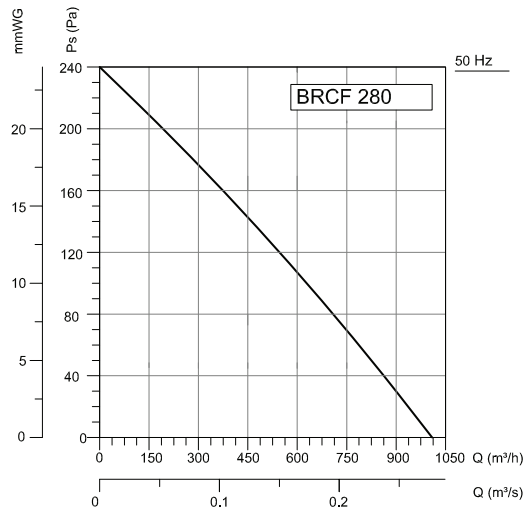

Frequency	Tot	63	125	250	500	1000	2000	4000	8000	Hz
L _{WA} Inlet	74	45	63	67	69	68	65	60	53	dB(A)
L _{WA} Surrounding	76	47	65	69	71	70	67	62	55	dB(A)

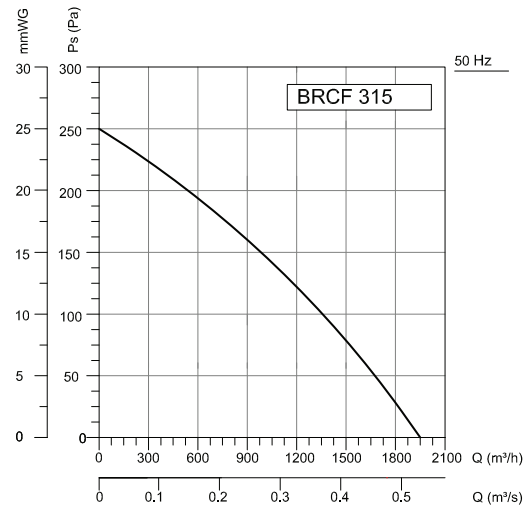

Frequency	Tot	63	125	250	500	1000	2000	4000	8000	Hz
L _{WA} Inlet	74	46	63	68	69	68	64	59	55	dB(A)
L _{WA} Surrounding	76	45	66	70	70	71	67	63	55	dB(A)

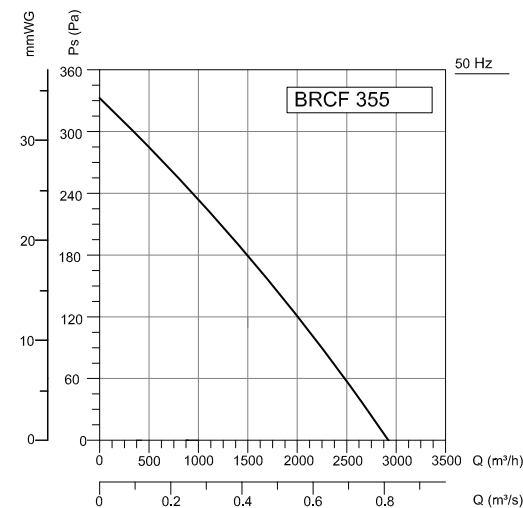

Frequency	Tot	63	125	250	500	1000	2000	4000	8000	Hz
L _{WA} Inlet	76	47	65	69	71	70	67	62	55	dB(A)
L _{WA} Surrounding	78	49	67	69	73	72	69	64	57	dB(A)

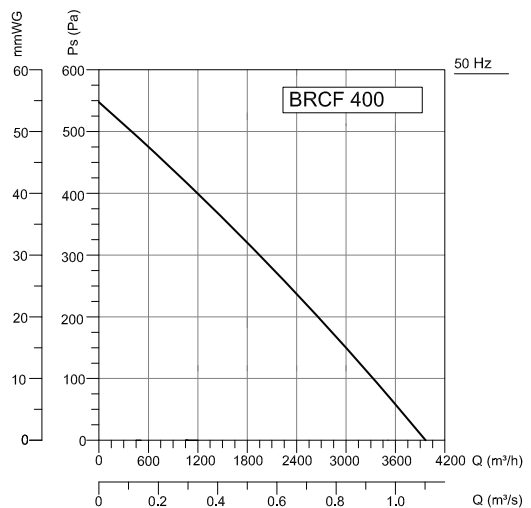

Frequency	Tot	63	125	250	500	1000	2000	4000	8000	Hz
L _{WA} Inlet	81	68	69	74	76	75	72	68	60	dB(A)
L _{WA} Surrounding	83	70	72	76	78	77	74	69	62	dB(A)

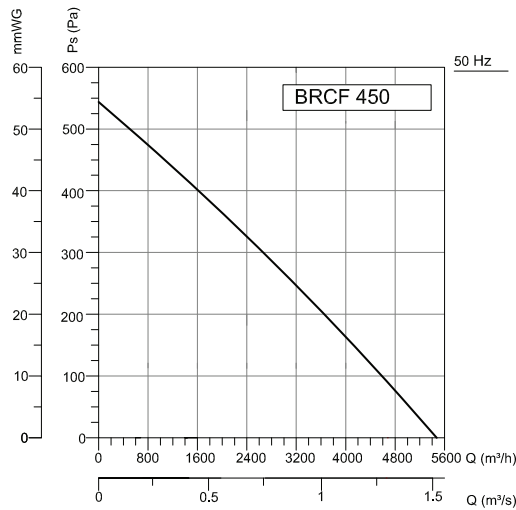

Frequency	Tot	63	125	250	500	1000	2000	4000	8000	Hz
L _{WA} Inlet	82	69	73	75	77	76	73	68	63	dB(A)
L _{WA} Surrounding	85	73	73	77	79	78	75	70	73	dB(A)

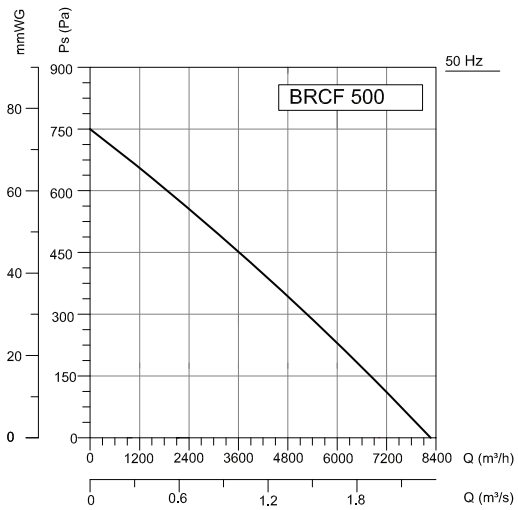

Frequency	Tot	63	125	250	500	1000	2000	4000	8000	Hz
L _{WA} Inlet	82	67	69	73	75	74	71	76	59	dB(A)
L _{WA} Surrounding	87	74	76	81	82	81	78	73	66	dB(A)

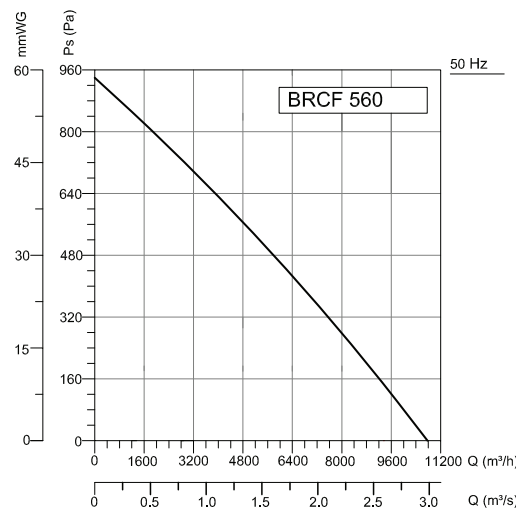

Frequency	Tot	63	125	250	500	1000	2000	4000	8000	Hz
L _{WA} Inlet	87	45	46	37	39	38	43	40	66	dB(A)
L _{WA} Surrounding	89	46	43	39	35	30	37	41	63	dB(A)

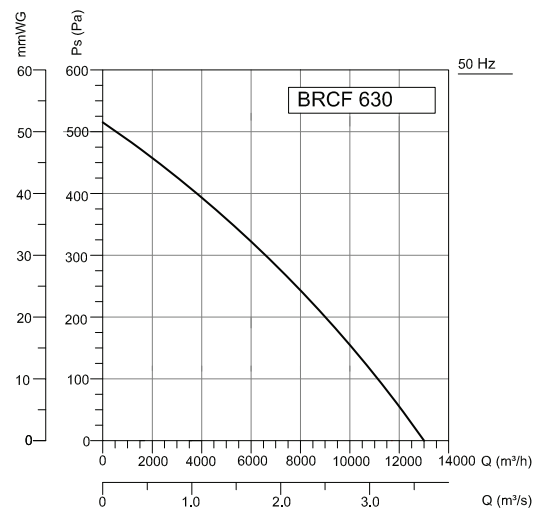

Frequency	Tot	63	125	250	500	1000	2000	4000	8000	Hz
L _{WA} Inlet	80	64	47	40	41	45	48	66	67	dB(A)
L _{WA} Surrounding	83	62	49	41	43	46	40	63	14	dB(A)

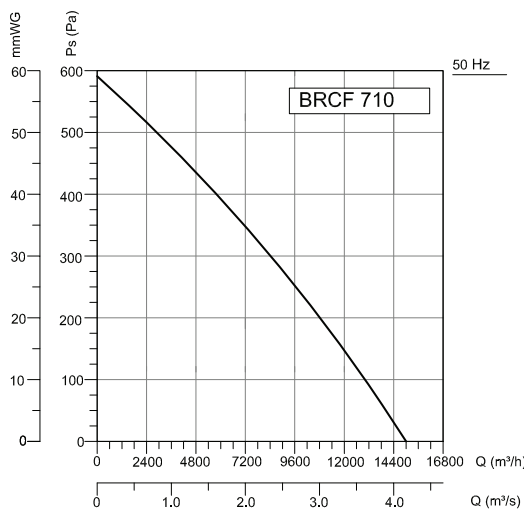

Frequency	Tot	63	125	250	500	1000	2000	4000	8000	Hz
L _{WA} Inlet	83	47	40	46	43	44	45	62	60	dB(A)
L _{WA} Surrounding	86	49	41	43	38	42	46	48	67	dB(A)

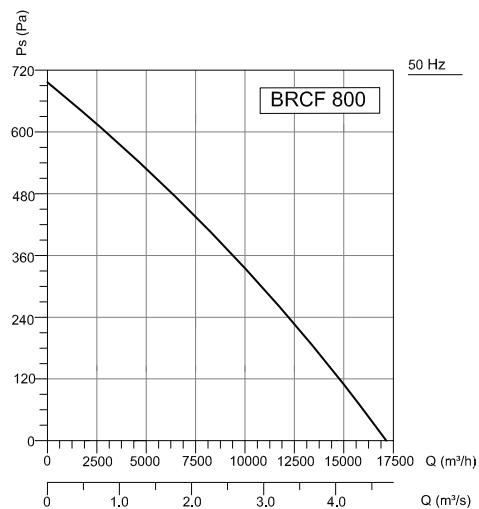

Frequency	Tot	63	125	250	500	1000	2000	4000	8000	Hz
L _{WA} Inlet	88	41	44	38	30	39	42	45	64	dB(A)
L _{WA} Surrounding	90	44	42	30	31	35	38	46	62	dB(A)