



BRCF-M

HORIZONTAL OUTLET ROOF FANS / Backward Curved

Fan Components and Material Properties

Body and hat made of electrostatic powder coated sheet metal. The BRCF-M 280 fan is made of high quality galvanized steel that is resistant to corrosion. The motor is external rotor with closed structure and is out of the airflow. The device is capable of carrying air at max.120°C.

Fan Structure

The fan blades are aerodynamically curved and provide regular flow. The fans are composed of backward sloping and infrequently arranged fins. Thanks to its aerodynamic wing structure, it works quietly.

Benefits

BRCF-M roof fans provide a great advantage in applications with vertical throw feature, especially in conditions where horizontally aspirated air cannot be disposed of. Thanks to the aerodynamic wing

structure, they work quietly. Speed can be adjusted with speed control devices. Since the motor is out of airflow, it is resistant to high temperature.

Speed Control

Optional control devices can be provided. Speed control with linear voltage regulator. (see BSC accessory)

Usage Areas

Industrial and commercial areas; it provides excellent solutions for smoke evacuation ventilation systems, especially for applications where the air must be transported at higher temperatures. It is used for ventilation of indoor spaces and kitchen areas. Due to its high temperature resistance, it is recommended to use the steam which is absorbed from the hoods by means of oil filter.

Technical Drawing and Tables

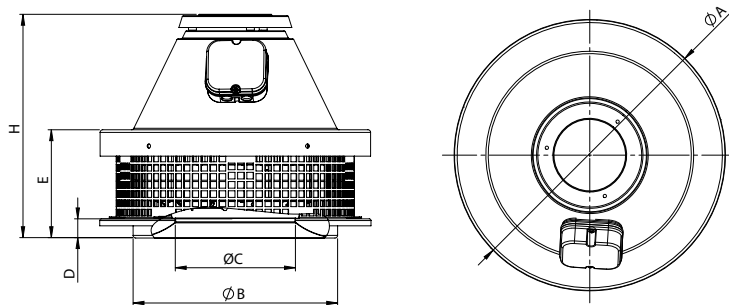

TYPE	A	B	C	D	E	H
BRCF-M 315	411	310	180	30	164	340

Dimensions are in (mm)

TYPE	VOLTAGE	FREQUENCY	POWER	CURRENT	CAPACITOR	SPEED	AIR FLOW	SOUND PRESSURE	INSULATION CLASS	PROTECTION CLASS	WEIGHT
	V	Hz	W	(A)	(µF)	r.p.m	m ³ /h	dB(A)	Ins.cl.	IP	kg
BRCF-M 315	230	50/60	185/280	0,82/1,23	5	2730/2980	1800/1965	56-48	F	44	11,3

The sound level is measured at a distance of 4-10 m in open field condition.

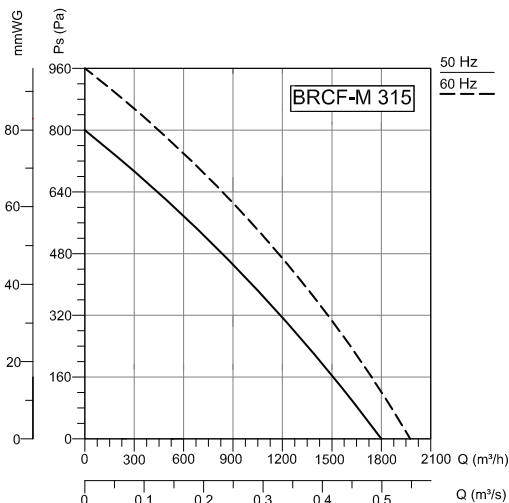

Accessories

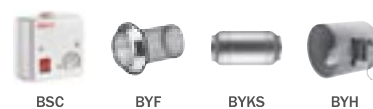

Frequency	Tot	63	125	250	500	1000	2000	4000	8000	Hz
L _{WA} Inlet	77	48	66	70	72	71	68	63	56	dB(A)
L _{WA} Surrounding	79	52	68	70	74	73	70	65	58	dB(A)