



User's manual

CONTENTS

Introduction	p. 3
Safety requirements	p. 3
Operating requirements	p. 4
Mounting	p. 4
Maintenance	p. 4
Transportation and storage	p. 4
Autotransformer speed controller (RSA)	
Use	p. 5
Delivery Set	p. 5
Main technical data	p. 5
Description and design	p. 5
Connection to power mains	p. 7
Typical faults and fault handling	p. 7
Speed controller (RS)	
Delivery Set	p. 8
Main technical data	p. 8
Designation key	p. 8
Main technical data	p. 8
Description and design	p. 9
Connection to power mains	p. 10
Minimum speed setting	p. 10
Typical faults and fault handling	p. 11
Fan speed switch (P)	
Use	p. 12
Delivery Set	p. 12
Designation key	p. 12
Main technical data	p. 12
Description and design	p. 13
Connection to power mains	p. 14
Typical faults and fault handling	p. 14
Timer (T)	
Use	p. 15
Delivery Set	p. 15
Designation key	p. 15
Main technical data	p. 16
Description and design	p. 16
Connection to power mains	p. 18
Typical faults and fault handling	p. 19
Wall surface mounting procedure	p. 20
Wall flush mounting procedure	p. 21
Manufacturer's warranty	p. 22
Acceptance certificate	p. 27
Warranty card	p. 28

The present operation manual consisting of the technical details, operating instructions and technical specification applies to the control unit enclosed in a versatile casing (UBR) and covers its installation as well as the regulations and warnings required for correct and safe operation of the product.

Disconnect the product from the power mains prior to all operations specific to connection, setup, maintenance and repair. The power mains connection must be performed by qualified personnel with valid permit for unassisted operations with electrical installations up to 1000 V after careful reading of the present operation manual. The single-phase mains which the product is to be connected to shall be compliant with the standing regulations. The stationary wiring shall be equipped with an automatic circuit breaker.

Connect the product to power mains through QF circuit breaker integrated into the stationary wiring with the contact gap on all poles at least 3 mm. Prior to connecting the unit to the power mains check it for visible damage as well as for any foreign objects in the unit casing.

RESTRICTIONS:

- The controller may only be used as intended. No modifications or alterations are allowed;
- Do not use the controller if the ambient air contains explosive or corrosive substances;
- Avoid moisture and splashes on the controller casing;
- Do not block the vents in the casing;
- Do not position the controller close to heating appliances.

The product is not to be used by children and persons with reduced physical, mental or sensory capacities, without proper practical experience or expertise, unless they are controlled or instructed on the product operation by the person(s) responsible for their safety.

Do not leave children unattended and do not let them play with the product.

Do not sit on the product and do not put objects on it.

Fulfil the requirements stated in this user's manual to ensure long service life of the product.

INTRODUCTION

SAFETY REQUIREMENTS

**OPERATION
REQUIREMENTS**

The product is rated for connection to single-phase AC 220-240 V, 50 Hz power mains. Ingress protection rating against access to hazardous parts and water ingress IP30. The product is rated for operation at the ambient temperature ranging from +1°C up to +45°C. The product is classified as Class II electric appliance.

MOUNTING

Both wall surface and flush mounting options are possible depending on the controller type. The controller is mounted using the screws and dowels included in the delivery set. The wall surface mounting sequence is shown in Fig. A-F (Page 20). The wall flush mounting sequence is shown in Fig. G-M (Page 21-22).

MAINTENANCE

Clean the product from any dust and dirt which may accumulate on the surfaces. Power off the product before performing any maintenance operations. For cleaning use a soft cloth and a brush soaked in an water detergent solution. Avoid any liquid on the electrical components. Wipe the cleaned surfaces dry.

**TRANSPORTATION
AND STORAGE**

Transportation of the product with any vehicle is allowed. The unit must be stored in the original packing at ambient air temperatures from +5°C to +40°C at relative air humidity not more than 80%. The storage environment must be free from dust and corrosive acid or alkaline vapours.



Recycle at the end of the service life.

Do not dispose the product with unsorted municipal trash.

RSA-0.3 autotransformer speed controller, hereinafter the controller, is designed for stepping the fan speed up or down by fluctuating the fan input voltage.

USE

The delivery set includes:

1. Controller - 1 item;
2. Self-tapping screws with dowels - 2 sets;
3. Spare fuse 0.4 A 250 V - 1 item;
4. User's manual;
5. Packing box.

DELIVERY SET

Input voltage, 50 Hz [V]	220-240
Output voltage [V]	230/200/180/160
Max. output power [VA]	60
Max. load current [A]	0,3
Dimensions [mm]	162x80x70
Weight [g]	650

**MAIN
TECHNICAL DATA**

The controller front panel is shown on fig. 1. The control knob position corresponds to the fan rotation speed. The control internal design is shown on fig .2.

**DESCRIPTION
AND DESIGN**

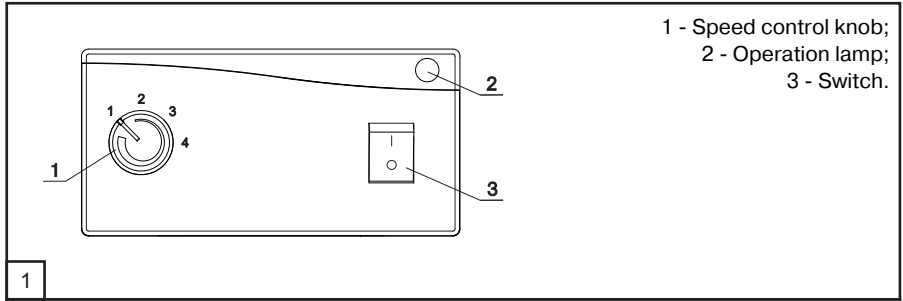

- 1 - Speed control knob;
- 2 - Operation lamp;
- 3 - Switch.

1

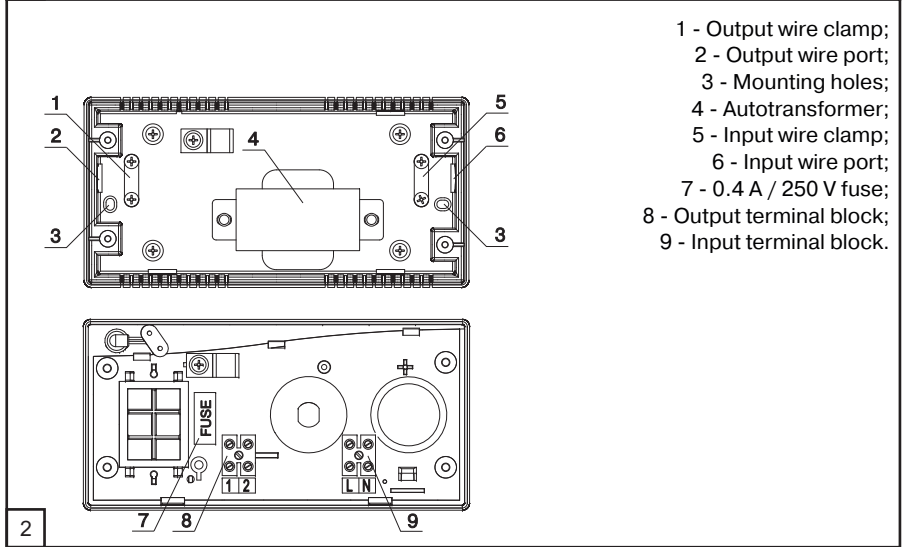

- 1 - Output wire clamp;
- 2 - Output wire port;
- 3 - Mounting holes;
- 4 - Autotransformer;
- 5 - Input wire clamp;
- 6 - Input wire port;
- 7 - 0.4 A / 250 V fuse;
- 8 - Output terminal block;
- 9 - Input terminal block.

2

To connect the controller to the power mains follow the wiring connection diagram, Fig. 3. Connection sequence:

- Remove the decorative front panel and the base, Fig. A and B;
- Route the wires through the ports 2, 6 in the controller casing;
- Strip the wire ends 7-8 mm long;
- Connect the wires to terminal blocks 8 and 9 (Fig. 2) according to the wiring connection diagram, Fig. 3;
- Secure the wires with clamps 1 and 5, Fig. 2;
- Re-install the base and the decorative front panel.

CONNECTION TO POWER MAINS

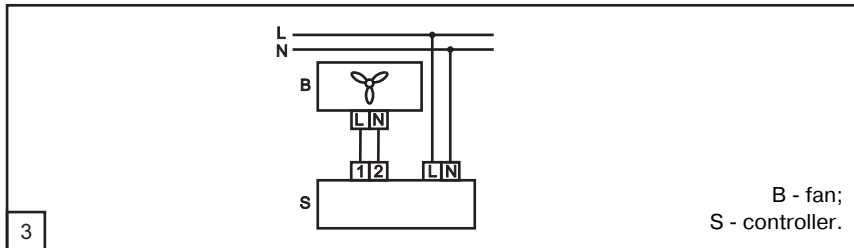

The controller starts operation immediately upon supplying the power voltage to its input. If the appliance fails to operate, refer to Table 1 for troubleshooting.

TYPICAL FAULTS AND FAULT HANDLING

FAULT	PROBABLE REASON	FAULT HANDLING
The appliance fails to operate	Limited or no power supply	Check the appliance connection (see Connection to power mains) and ensure secure contact on the terminal blocks.
	Blown fuse	Replace the fuse.

TABLE 1

USE

RS thyristor speed regulator (SR), hereinafter the controller, is designed for continuous smooth fan speed control.

DELIVERY SET

The delivery set includes:

1. Controller - 1 item;
2. Self-tapping screws with dowels: 2 sets for wall surface mounting;
4 sets for wall flush mounting;
3. Spare fuse - 1 item;
- 1.5 A (for RS-1), 2.0 A (for RS-1.5), 2.5 A (for RS-2), 3.15 A (for RS-2.5) - 1 item;
4. Plastic screwdriver - 1 item;
5. User's manual;
6. Packing box.

DESIGNATION KEY
RS-X X

Mounting option: _____

N - wall surface mounting;
V - wall flush mounting

Maximum current [A]: _____

1; 1.5; 2; 2.5

Designation key example:

RS - 1 N - speed controller with maximum current 1 A for wall surface mounting.

MAIN TECHNICAL DATA

Appliance type	RS-1	RS-1,5	RS-2	RS-2,5
Input voltage, 50 Hz [V]	220-240			
Max. output power [VA]	230	345	460	575
Max. load current [A]	1	1,5	2	2,5
Overall dimensions [mm]	162x80x70			
Weight [g]	300			

The controller front panel is shown on fig. 4.
The control knob position corresponds to the fan rotation speed.
The control internal design is shown on fig .5.

**DESCRIPTION
AND DESIGN**

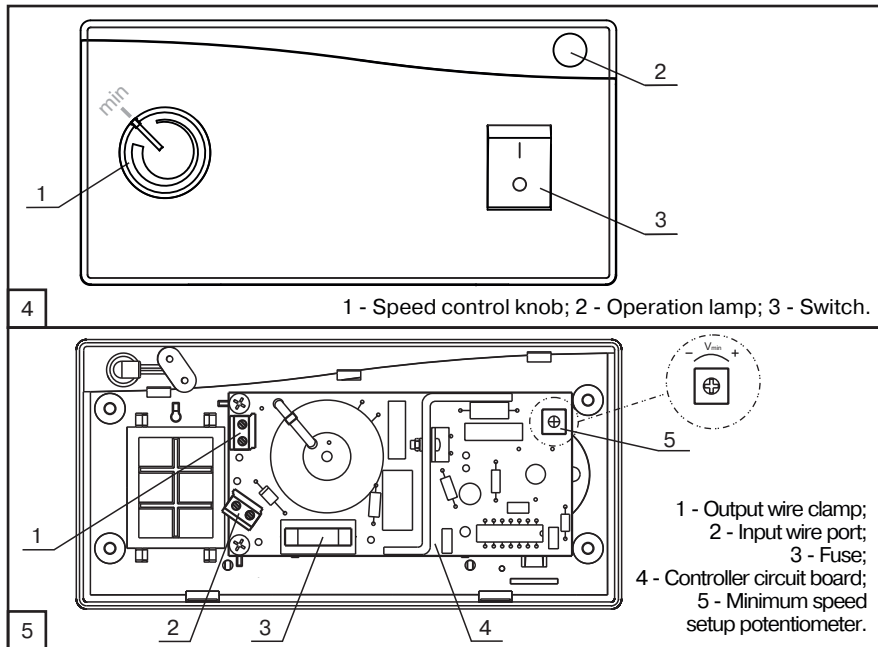

CONNECTION TO POWER MAINS

To connect the speed controller to the power mains follow the wiring connection diagram, Fig. 6.

Connection sequence:

- Remove the decorative front panel and the base, Fig. A and B;
- Route the wires through the ports 2, 6 in the controller casing;
- Strip the wire ends 7-8 mm long;
- Connect the wires to terminal blocks 8 and 9 (Fig. 2) according to the wiring connection diagram, Fig. 3;
- Secure the wires with clamps 1 and 5, Fig. 2;
- Re-install the base and the decorative front panel.

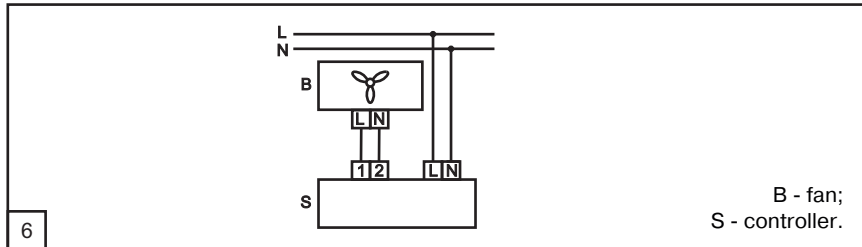

MINIMUM SPEED SETTING

On the initial start set up the minimum speed of the connected fan.

To set the minimum rotation speed set the control knob 1, Fig. 4 on the front panel to the leftmost position and then gently rotate the control knob of potentiometer 5, Fig. 5 with the plastic screwdriver (included into the delivery) to the right or to the left until the fan starts rotating steadily.

The controller starts operation immediately upon supplying the power voltage to its input. If the appliance fails to operate, refer to Table 2 for troubleshooting.

**TYPICAL FAULTS
AND FAULT
HANDLING**

FAULT	PROBABLE REASON	FAULT HANDLING
The appliance fails to operate	Limited or no power supply	Check the appliance connection (see Connection to power mains) and ensure secure contact on the terminal blocks.
	Blown fuse.	Replace the fuse.

TABLE 2

USE

The fan speed switch, hereinafter referred as the switch, is designed for control of the rotation speed of multi-speed fans.

DELIVERY SET

The delivery set includes:

1. Controller - 1 item;
2. Self-tapping screws with dowels:
 - 2 sets for wall surface mounting;
 - 4 sets for wall flush mounting;
3. User's manual;
4. Packing box.

**DESIGNATION
KEY**
PX-5.0 X

Mounting option:

N - wall surface mounting;

V - wall flush mounting

Maximum current [A]:

5,0

Number of selectable switch positions

2; 3; 5

Designation key example:

P3-5.0 N - 3 position speed switch, maximum load current 5 A, intended for wall surface installation.

**MAIN
TECHNICAL DATA**

Input voltage, 50 Hz [V]	220-240
Max. output power [VA]	1000
Max. load current [A]	5,0
Overall dimensions [mm]	162x80x70
Weight [g]	250

The switch front panel is shown on Fig. 7.
The switch knob position corresponds to the fan rotation speed.
The switch internal design is shown on Fig. 8.

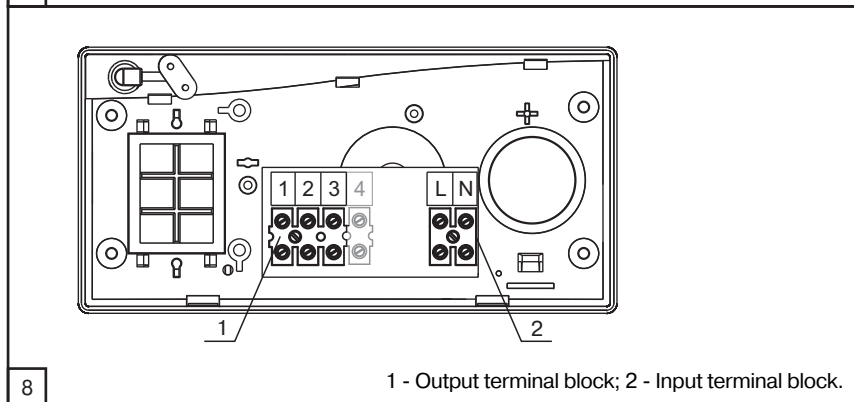
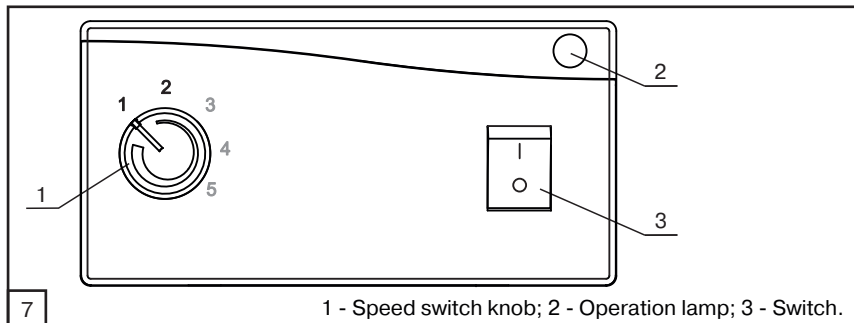
**DESCRIPTION
AND DESIGN**

To connect the speed switch to the power mains follow the wiring connection diagram, Fig. 9. The switch may be connected to several fans provided that the total power consumption is below 1000 VA.

Connection sequence:

- Remove the decorative front panel and the base, Fig. A and B;
- Route the wires through the ports in the speed switch casing;
- Strip the wire ends 7-8 mm long;
- Connect the wires to terminal blocks according to the wiring connection diagram, Fig. 9;
- Re-install the base and the decorative front panel.

CONNECTION TO POWER MAINS

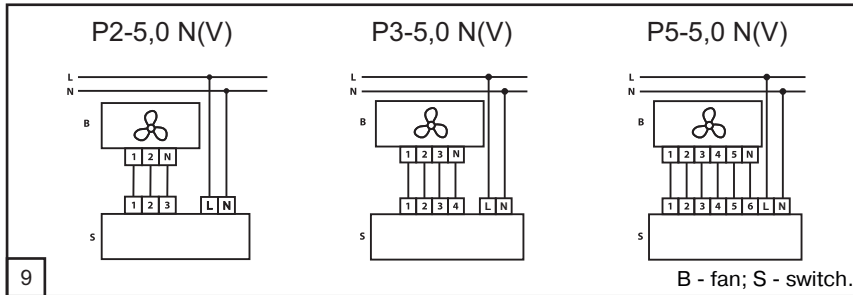

The switch starts operation immediately upon supplying the power voltage to its input. If the appliance fails to operate, refer to Table 3 for troubleshooting.

TYPICAL FAULTS AND FAULT HANDLING

FAULT	PROBABLE REASON	FAULT HANDLING
The appliance fails to operate	Limited or no power supply	Check the appliance connection (see Connection to power mains) and ensure secure contact on the terminal blocks.

TABLE 3

The timer in the versatile casing is designed for the fan control depending on humidity and light conditions, actuation of the external switch or motion registration.

USE

The delivery set includes:

1. Controller - 1 item;
2. Self-tapping screws with dowels: 2 sets for wall surface mounting;
4 sets for wall flush mounting;
3. User's manual;
4. Packing box.

DELIVERY SET

XX-1,5-X

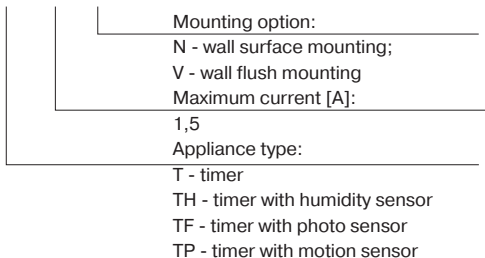
**DESIGNATION KEY**

Designation key example:

TH-1.5-H - timer with humidity sensor, maximum current load 1.5 for wall surface mounting.

**MAIN
TECHNICAL DATA**

Input voltage, 50 Hz [V]	220-240
Max. output power [VA]	330
Max. load current [A]	1,5
Overall dimensions [mm]	162x80x70
Weight [g]	400

**DESCRIPTION
AND DESIGN**

The control unit front panel is shown in Fig. 10.

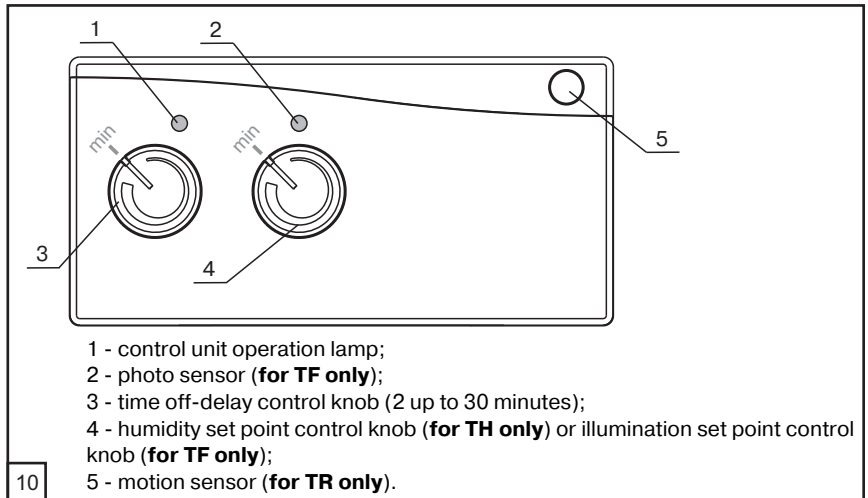

The timer is available in four modifications:

Timer (T)

The control unit supplies voltage to the connected fan after the external switch, e.g. the light switch, supplies control signal to the input terminal LT. After the control voltage is off, the control unit continues to supply power to the fan within the time period set by the timer (2 ... 30 min).

Timer with humidity sensor (TH)

The control unit supplies voltage to the connected fan after the external switch, e.g. the light switch, supplies control signal to the input terminal LT or if the indoor humidity exceeds the set point (60% ... 90%). After the control voltage is off or after the humidity falls below the set point, the control unit continues to supply power to the fan within the time period set by the timer (2 ... 30 min).

Timer with photo sensor (TF)

The control unit supplies voltage to the connected fan after the external switch, e.g. the light switch, supplies control signal to the input terminal LT or if the lighting intensity exceeds the set point. After the control voltage is off or after the lighting intensity falls below the set point, the control unit continues to supply power to the fan within the time period set by the timer (2 ... 30 min).

Timer with motion sensor (TP)

The control unit supplies voltage to the connected fan after the external switch, e.g. the light switch, supplies control signal to the input terminal LT or in case of motion detection at a distance from 1 to 4 m and the horizontal viewing angle of 100°. After the control voltage is off or after no more motion is detected, the control unit continues to supply power to the fan within the time period set by the timer (2 ... 30 min).

The off-delay time, humidity and lighting set point are regulated with the control knobs on the front panel.

**OPERATION
MODES AND
INDICATION**

The control unit has three operation modes:

1. **Standby mode** - the control unit operation mode in case of no signals from the sensor or the external swath.

The fan is off. The operation lamp blinks once in 5 seconds.

2. **Active mode** - the operation mode is activated by the motion sensor, external swath closing, exceeding humidity or illumination set point.

The fan operates. The operating lamp has permanent glow.

3. **Timer operation** - the control unit operation mode that is activated in case of no motion detection, external switch opening, humidity or illumination decrease below the set point. The runout time is individually adjustable.

The fan runs. The operating lamp blinks once in 1 second.

The control unit has the connected load monitoring function:

1. In case of the regular current load up to 1.5 A the operating lamp is green.

2. In case of the load current from 1.5 A up to 1.9 A the operating lamp is red.

This current load leads to heavy duty operation conditions. The control unit operates at increased load which may result decreased service life of the appliance.

It is recommended to reduce the connected load below 1.5 A.

3. In case of the load current above 1.9 A the operating lamp blinks red 5 times in second. That is an emergency operation mode. The load is disconnected automatically.

To revert to the standard operation mode disconnect the control unit from power mains at least for 10 seconds and connect the fan with the current consumption below 1.5 A.

To connect the speed switch to the power mains follow the wiring connection diagram, Fig. 12.

Connection sequence:

- Remove the decorative front panel and the base, Fig. A and B;
- Route the wires through the ports in the control unit casing;
- Strip the wire ends 7-8 mm long;
- Connect the wires to terminal blocks 1, 2, Fig. 11 according to the wiring connection diagram, Fig. 12;
- Re-install the base and the decorative front panel.

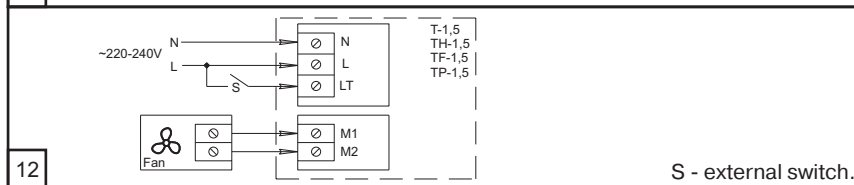
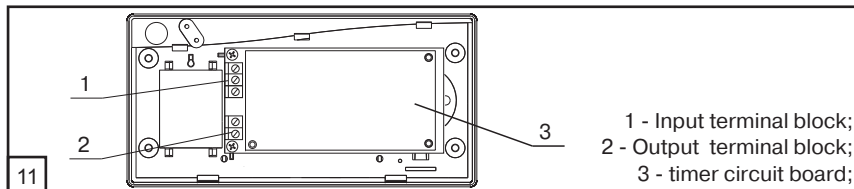

The control unit starts operation immediately upon supplying the power voltage to its input. If the appliance fails to operate, refer to Table 4 for troubleshooting.

FAULT	PROBABLE REASON	FAULT HANDLING
The appliance fails to operate	Limited or no power supply	Check the appliance connection (see Connection to power mains) and ensure secure contact on the terminal blocks.

TABLE 4

CONNECTION TO POWER MAINS

TYPICAL FAULTS AND FAULT HANDLING

**WALL SURFACE
MOUNTING**

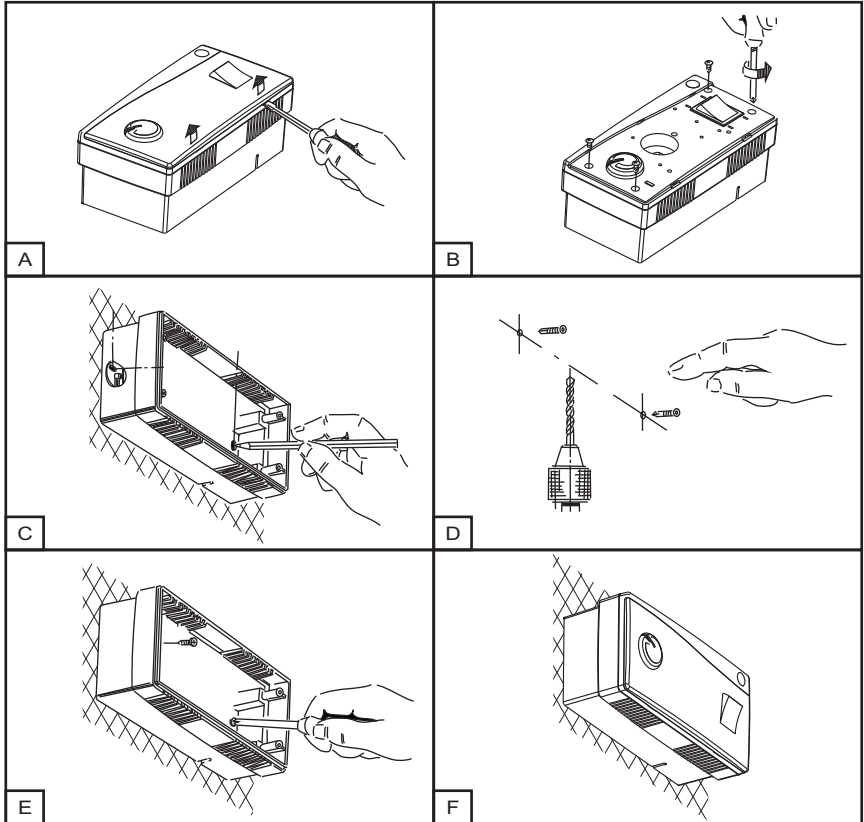

WALL FLUSH MOUNTING

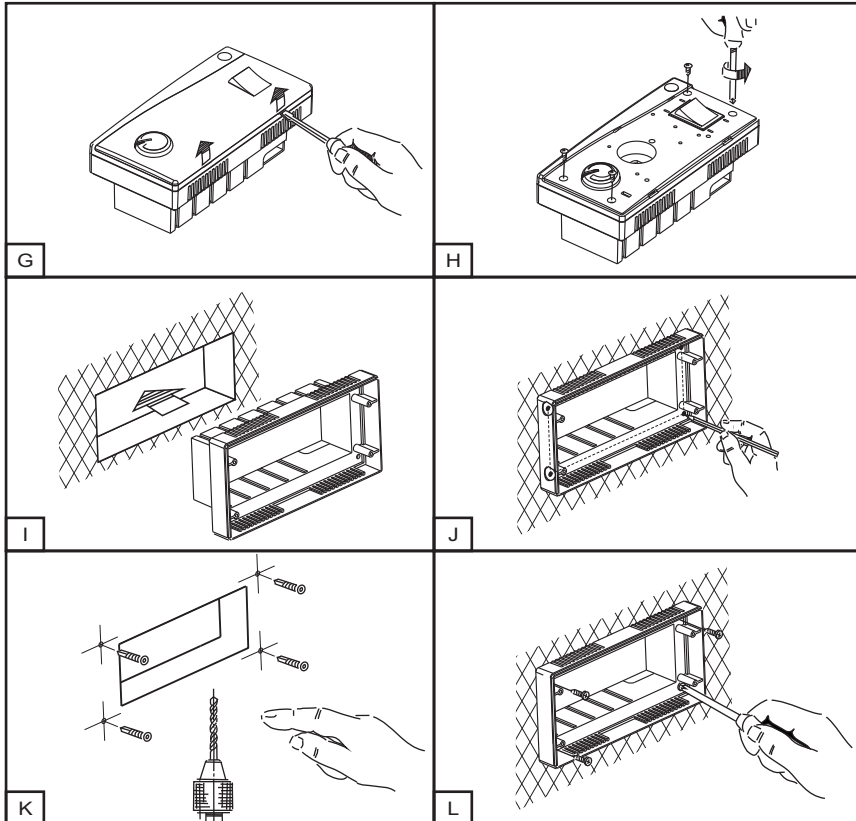

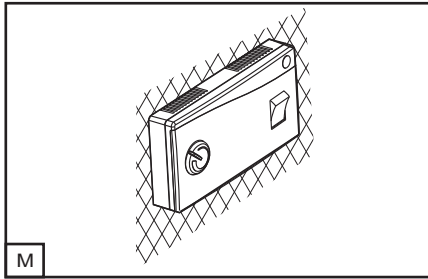

The fan is manufactured at the factory of “Ventilation systems” PrJSC (hereinafter referred to as the Manufacturer).

MANUFACTURER'S WARRANTY

By purchasing this product the customer confirms to have read and agreed to the terms, rules and requirements related to operation, storage, transportation, mounting, adjustment, connection, maintenance and repair as well as warranty obligations with respect to this product as set forth in the manufacturer's accompanying documentation to the product. The manufacturing company sets forth the warranty period (service life) of the product as 12 months following the sale date via retail network subject to the customer's ensuring compliance with the rules of transportation, storage, mounting and operation of the product.

In case of any malfunction of the product through the fault of the Manufacturing company within the warranty period (service life), the customer shall have the right to elimination of the manufacturing defects by means of warranty servicing performed free of charge. The warranty servicing implies performance of activities related to elimination of defects in the product aimed to provide intended use of the product by the customer. The defects are eliminated either by replacing or repairing such a product or a part (component) thereof.

NOTE: with the purpose of performing warranty servicing you please produce User Manual or other relevant substituting document and the payment document as an evidence of the purchase with indication of the sale date. The product model shall comply with that one specified in the User Manual or other relevant substituting document.

With the purpose of performing warranty servicing please contact the trade company where you purchased the product. If warranty servicing on the spot proves impossible, you will be provided with the necessary information regarding rendering of this service.

Manufacturer's warranty shall not apply in the following cases:

- in case the customer fails to provide the product in complete according to the package contents specified in the User Manual or other relevant substituting document, including any components disassembled by the customer;
- in case of incompliance of the model or marking of the product with data specified on the product packaging and in the User Manual or other relevant substituting document;
- in case of non-timely technical maintenance of the product by the customer (dust, mud, oil condensate, foreign particles);
- in case of causing external damage to the product by the customer ('damage' shall not apply to external changes of the product required for the product mounting);
- in case of altering the product design or further reworking of the product;
- in case of replacing and using parts, units and components of the product not prescribed by the manufacturing company;
- in case of other use of the product other than intended use;
- in case of the customer's violating product operation rules;
- in case of connecting the product to electric mains of voltage exceeding voltage value specified in the user's manual;
- in case of step voltage that resulted in the product failure;
- in case of the customer's performing unauthorised repair of the product;
- in case of performing repair of the product by third persons unauthorized by the manufacturing company;

in case of warranty period (service life) expiry;
in case of the customer's violating transportation rules assuring prevention of damaging and/or destruction of the product;
in case of the customer's violating product storage rules;
in case of performing unlawful actions by third persons with respect to the product;
in case of force majeure (fire, flood, earthquake, war, hostilities of any kind, blockade);
in case of absent seals, provided such seals are prescribed by the User Manual or other relevant substituting document;
in case of unavailable warranty card;
in case of unavailable payment document to confirm the purchase with indication of the sale date.

The manufacturing company shall be responsible for defects arising through its fault prior to the moment of transferring the product to the ownership of the customer.

The manufacturing company shall not be responsible for defects arising after transferring the product to the customer and caused by the customer's violating the rules of transportation, storage, assembly and operation of the product, or by actions of third persons, an accident or force majeure circumstances.

The manufacturing company shall not be responsible for damage to health and property of the customer caused by the customer's violating the User Manual or other relevant substituting document; other use of the product by the customer other than its intended use, or by failure of the customer to comply with warnings and other information on the product specified in the User Manual or other relevant substituting document, or by the customer's violating the rules of transportation, storage, mounting, maintenance and operation of the product.

**Autotransformer speed controller
Thyristor speed controller**

**RSA-0.3
RS-1 N
RS-1 V
RS-1,5 N
RS-1,5 V
RS-2 N
RS-2 V
RS-2,5 N
RS-2,5 V**

**ACCEPTANCE
CERTIFICATE**

Fan speed switch

**P2-5.0 N
P2-5.0 V
P3-5.0 N
P3-5.0 V
P5-5.0 N
P5-5.0 V**

Control unit

**T-1.5 N
T-1.5 V
TH-1.5 N
TH-1.5 V
TF-1.5 N
TF-1.5 V
TP-1.5 N
TP-1.5 V**

is recognized as serviceable

mark the proper model

Approval mark

Sold
(name and stamp of the trade company)

Manufacturing date

Date of sale

Μιχαήλ Καραολή 19, τκ 143 43, Ν. Χαλκηδόνα, Αθήνα
Τηλ: 211 - 70.55.500 & 210 - 21.30.051, Fax: 210 - 22.23.283

**WARRANTY
CARD**
