

USER'S MANUAL

DVUT 300 PB EC
DVUT 300 PBE EC
DVUT 300 PBE2 EC
DVUT 300 P1B EC
DVUT 300 P1BE EC
DVUT 300 P1BE2 EC

DVUT 500 PB EC
DVUT 500 PBE EC
DVUT 500 PBE2 EC
DVUT 500 P1B EC
DVUT 500 P1BE EC
DVUT 500 P1BE2 EC

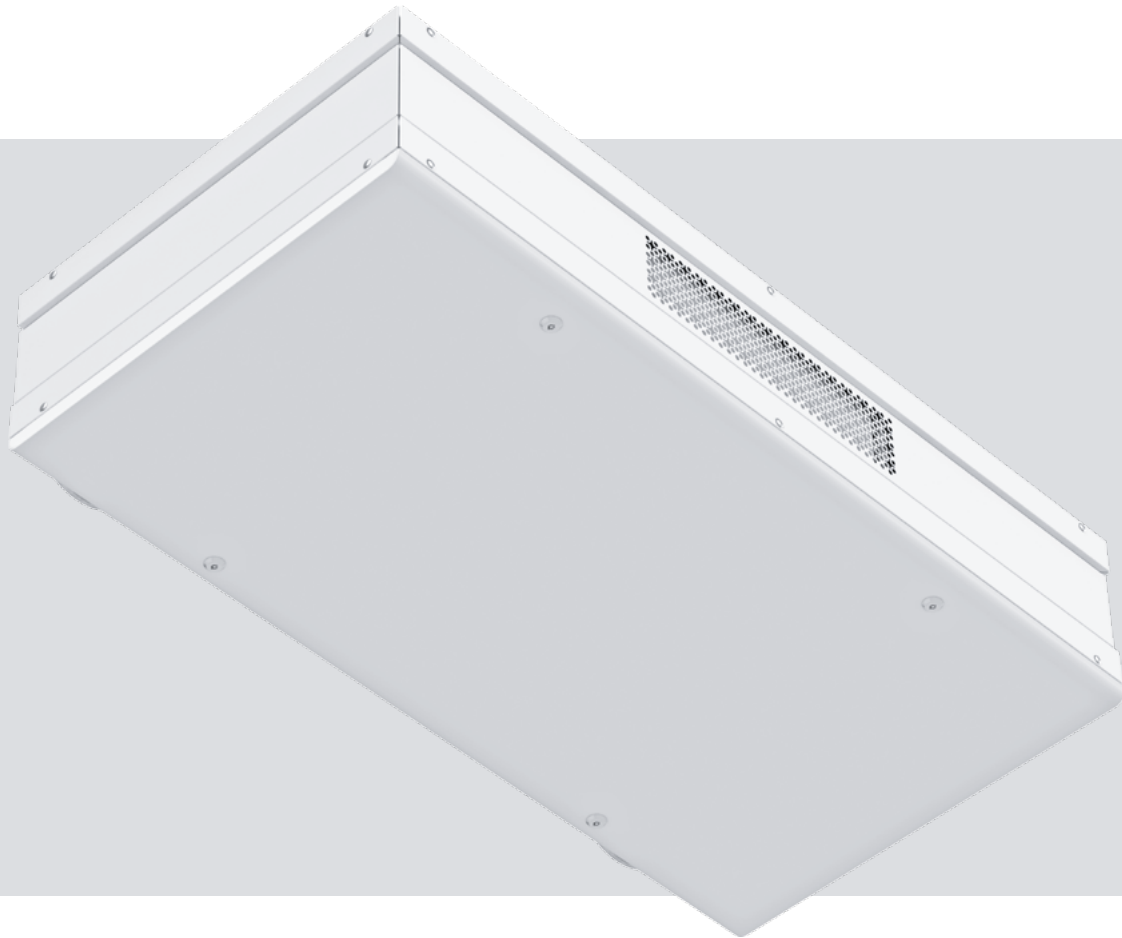

Single-room air handling unit

CONTENTS

Safety requirements.....	2
Purpose.....	4
Delivery set.....	4
Designation key.....	4
Technical data.....	5
Design and operating principle.....	7
Installation and set-up.....	10
Connection to power mains.....	18
Control.....	19
Technical maintenance.....	19
Troubleshooting.....	21
Storage and transportation regulations.....	21
Manufacturer's warranty.....	22
Certificate of acceptance.....	23
Seller information.....	23
Installation certificate.....	23
Warranty card.....	23

This user's manual is a main operating document intended for technical, maintenance, and operating staff.

The manual contains information about purpose, technical details, operating principle, design, and installation of the DVUT P(1)B EC unit and all its modifications.

Technical and maintenance staff must have theoretical and practical training in the field of ventilation systems and should be able to work in accordance with workplace safety rules as well as construction norms and standards applicable in the territory of the country.

The information in this user's manual is correct at the time of the document's preparation.

The Company reserves the right to modify the technical characteristics, design, or configuration of its products at any time in order to incorporate the latest technological developments.

No part of this publication may be reproduced, stored in a retrieval system, or transmitted, in any form or by any means in any information search system or translated into any language in any form without the prior written permission of the Company.

SAFETY REQUIREMENTS

- Please read the user's manual carefully prior to installing and operating the unit.
- All user's manual requirements as well as the provisions of all the applicable local and national construction, electrical, and technical norms and standards must be observed when installing and operating the unit.
- The warnings contained in the user's manual must be considered most seriously since they contain vital personal safety information.
- Failure to follow the rules and safety precautions noted in this user's manual may result in an injury or unit damage.
- After a careful reading of the manual, keep it for the entire service life of the unit.
- While transferring the unit control, the user's manual must be turned over to the receiving operator.

UNIT INSTALLATION AND OPERATION SAFETY PRECAUTIONS



- Disconnect the unit from power mains prior to any installation operations.



- Unpack the unit with care.



- The unit must be grounded!



- While installing the unit, follow the safety regulations specific to the use of electric tools.



- Do not change the power cable length at your own discretion.
- Do not bend the power cable.
- Avoid damaging the power cable.
- Do not put any foreign objects on the power cable.



- Do not lay the power cable of the unit in close proximity to heating equipment.

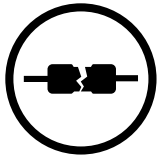

- Do not use damaged equipment or cables when connecting the unit to power mains.



- Do not operate the unit outside the temperature range stated in the user's manual.
- Do not operate the unit in aggressive or explosive environments.



- Do not touch the unit controls with wet hands.
- Do not carry out the installation and maintenance operations with wet hands.



- Do not wash the unit with water.
- Protect the electric parts of the unit against ingress of water.



- Do not allow children to operate the unit.

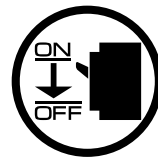

- Disconnect the unit from power mains prior to any technical maintenance.



- Do not store any explosive or highly flammable substances in close proximity to the unit.



- When the unit generates unusual sounds, odour, or emits smoke, disconnect it from power supply and contact the Seller.

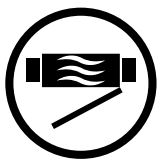

- Do not open the unit during operation.



- Do not direct the air flow produced by the unit towards open flame or ignition sources.



- Do not block the air duct when the unit is switched on.



- In case of continuous operation of the unit, periodically check the security of mounting.

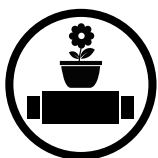

- Do not sit on the unit and avoid placing foreign objects on it.

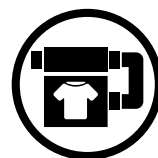

- Use the unit only for its intended purpose.



**THE PRODUCT MUST BE DISPOSED SEPARATELY AT THE END OF ITS SERVICE LIFE.
DO NOT DISPOSE THE UNIT AS UNSORTED DOMESTIC WASTE.**

PURPOSE

The unit is designed to ensure continuous mechanical air exchange in houses, offices, hotels, cafes, conference halls, and other utility and public spaces as well as to recover the heat energy contained in the air extracted from the premises to warm up the filtered stream of intake air.

The unit is not intended for organizing ventilation in swimming pools, saunas, greenhouses, summer gardens, and other spaces with high humidity.

Due to the ability to save heating energy by means of energy recovery, the unit is an important element of energy-efficient premises.

The unit is a component part and is not designed for stand-alone operation. It is rated for continuous operation.

Transported air must not contain any flammable or explosive mixtures, evaporation of chemicals, sticky substances, fibrous materials, coarse dust, soot and oil particles or environments favourable for the formation of hazardous substances (toxic substances, dust, pathogenic germs).



THE UNIT SHOULD NOT BE OPERATED BY CHILDREN OR PERSONS WITH REDUCED PHYSICAL, MENTAL, OR SENSORY CAPACITIES, OR THOSE WITHOUT THE APPROPRIATE TRAINING.

THE UNIT MUST BE INSTALLED AND CONNECTED ONLY BY PROPERLY QUALIFIED PERSONNEL AFTER THE APPROPRIATE BRIEFING.

THE CHOICE OF UNIT INSTALLATION LOCATION MUST PREVENT UNAUTHORIZED ACCESS BY UNATTENDED CHILDREN.

DELIVERY SET

NAME	NUMBER
Air handling unit	1 pc.
User's manual	1 pc.
Control panel	1 pc.
User's manual (control panel)	1 pc.
Key to a service panel	1 pc.
Mounting bracket	1 pc.
Mounting L-bracket	4 pcs.
Mounting template	1 pc.
Packing box	1 pc.

DESIGNATION KEY

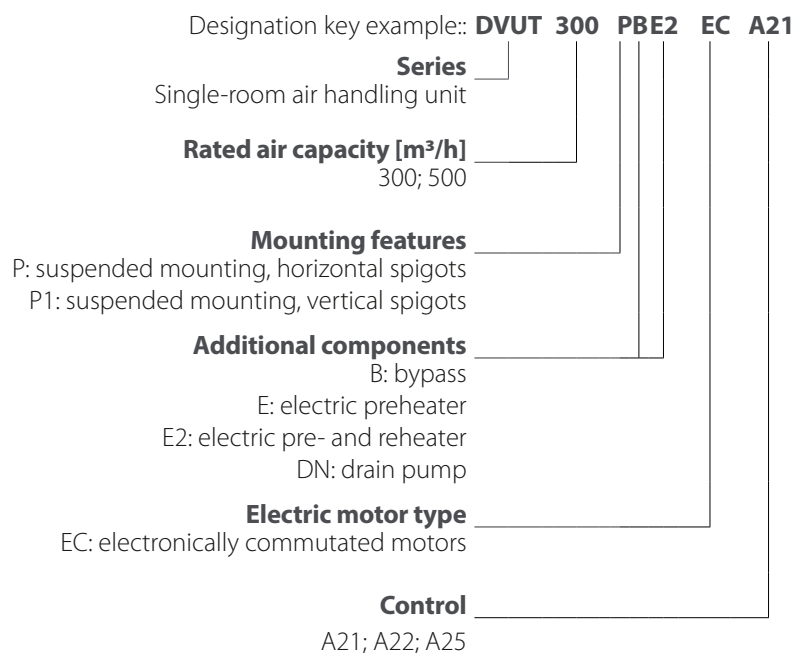

TECHNICAL DATA

The unit is designed for application with the ambient temperature ranging from +1 °C to +40 °C and relative humidity up to 80 %. In order to prevent condensation on the internal walls of the unit, it is necessary that the surface temperature of the casing is 2-3 °C above the dew point temperature of the transported air.

The unit is rated as a Class I electrical appliance.

Hazardous parts access and water ingress protection rating:

- IP22 for the unit connected to the air ducts;
- IP44 for the unit motors.

The unit design is constantly being improved, thus some models may be slightly different from those described in this manual.

Parameter	300 mm						500 mm					
	DVUT 300 PB EC	DVUT 300 P1B EC	DVUT 300 PB EC	DVUT 300 P1B EC	DVUT 300 PBE2 EC	DVUT 300 P1BE2 EC	DVUT 500 PB EC	DVUT 500 P1B EC	DVUT 500 PB EC	DVUT 500 P1B EC	DVUT 500 PBE2 EC	DVUT 500 P1BE2 EC
Power supply voltage, 50 (60) Hz [V]	1~230						1~230					
Maximum unit power without electric heater [W]	125						170					
Preheater power [W]	-	1050					-	1750				
Reheater power [W]	-	-	1400				-	-	1750			
Maximum unit current without electric heater [A]	1,3						1,25					
Maximum unit current with electric heater [A]	-	7,3	13,6				-	10,4	18,2			
Max. air flow [m ³ /h]	300						510					
RPM [min ⁻¹]	2150						1700					
Sound pressure level at 3 m [dBA]	22						24					
Maximum transported air temperature [°C]	-25...+40						-25...+40					
Casing material	painted steel						painted steel					
Insulation	30 mm, polyester						30 mm, polyester					
Extract air filter	G4						G4					
Supply air filter	G4, F8 (optional: F8 C + H13)						G4, F8 (optional: F8 C + H11)					
Connected duct diameter [mm]	200						250					
Weight [kg]	78	119	79	121	80	123	126	163	128	165	130	167
Heat recovery efficiency [%]	76...88						74...86					
Heat exchanger type	counter-flow						counter-flow					
SEC class	A		A		A		A		A		A	

Model	Dimensions [mm]									
	D	A	A1	A2	B	B1	H	H1	H2	H3
DVUT 300 PB EC	200	1547	1155	196	818	873	333	347	145	188
DVUT 300 PBE EC										
DVUT 300 PBE2 EC			1100		1101			399		
DVUT 300 P1B EC										
DVUT 300 P1BE EC										
DVUT 300 P1BE2 EC										
DVUT 500 PB EC	250	1806	1316	244	1018	1083	386	400	169	217
DVUT 500 PBE EC										
DVUT 500 PBE2 EC			1314		1349			462		
DVUT 500 P1B EC										
DVUT 500 P1BE EC										
DVUT 500 P1BE2 EC										

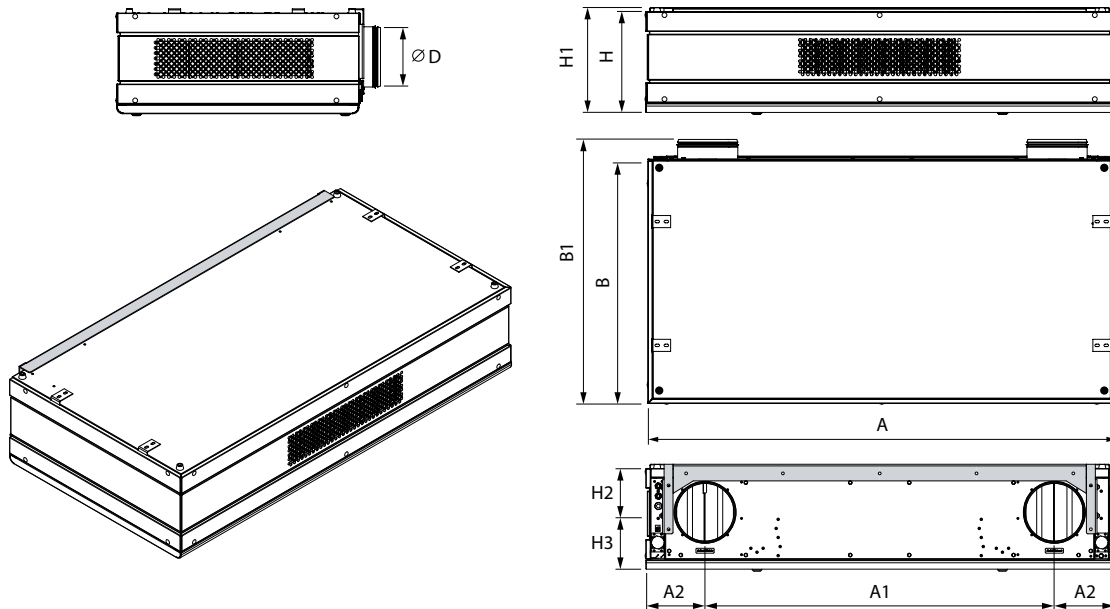
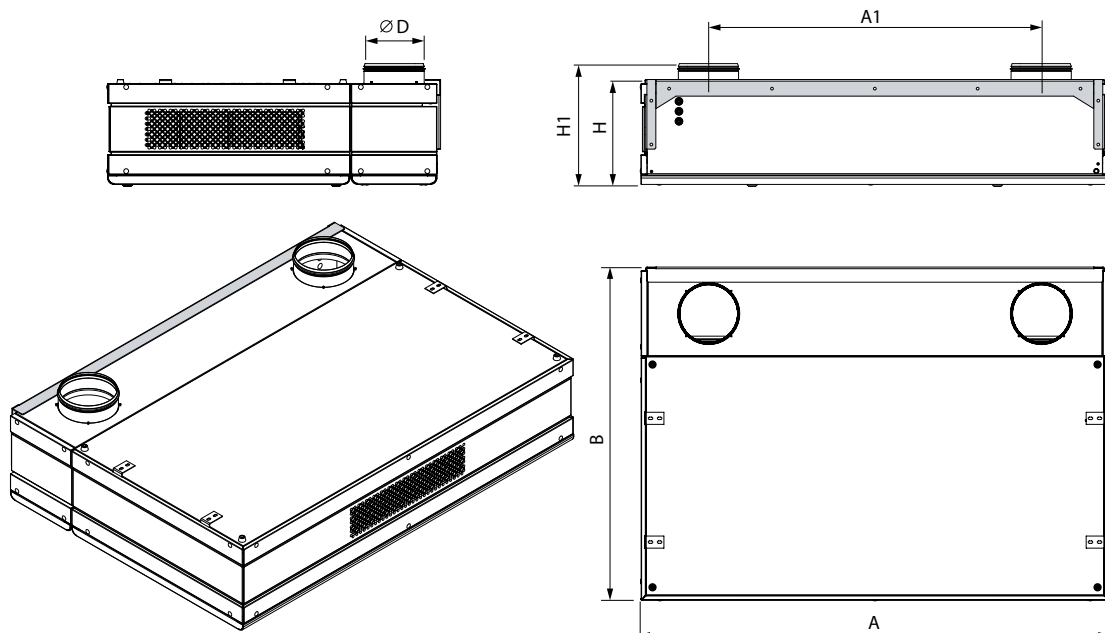
UNIT WITH HORIZONTAL SPIGOTS

UNIT WITH VERTICAL SPIGOTS

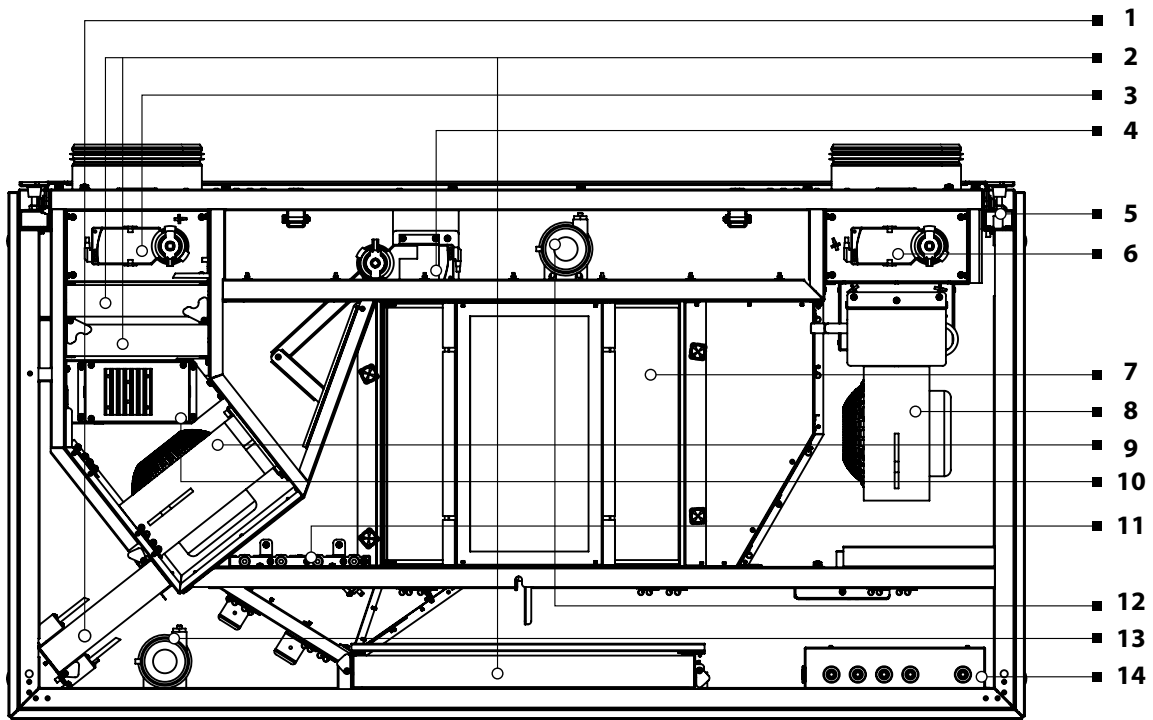
DESIGN AND OPERATING PRINCIPLE



	DVUT P(1)B EC (A21, A22, A25)	DVUT P(1)BE EC (A21, A22, A25)	DVUT P(1)BE2 EC (A21, A22, A25)
1 Extract air filter	■	■	■
2 Supply air filter	■	■	■
3 Supply air damper actuator	■	■	■
4 Bypass damper actuator	■	■	■
5 Drain pipe	■	■	■
6 Extract air damper actuator	■	■	■
7 Heat exchanger	■	■	■
8 Extract fan	■	■	■
9 Supply fan	■	■	■
10 Supply air electric preheater		■	■
11 Supply air electric reheater			■
12 Differential pressure switch for supply filter contamination control	■	■	■
13 Differential pressure switch for extract filter contamination control	■	■	■
14 Control unit	■	■	■

Warm extract air from the room flows into the unit and is cleaned in the extract filter. Then the air is moved through the heat exchanger and is exhausted outside with the extract fan. Cold fresh air from outside flows through the air duct into the unit, where it is cleaned by the supply filter. Then the air flows through the heat exchanger and is moved to the room by the supply fan. Supply air is heated in the heat exchanger due to transfer of the heat energy of warm and humid extract air to the cold fresh air. The air streams remain separated in the heat exchanger. Heat recovery minimizes heat losses, which reduces costs for space heating in the cold season.

The swivel service door with locks provides convenient service access for maintenance of the unit.

The heat exchanger freeze protection mode is provided in the unit:

- Via automatic shut-down of the supply fan.
- Via bypass air duct with a bypass damper. The bypass damper opens automatically the bypass air duct, directing the supply air flow bypassing the heat exchanger.
- Via automatic turning the supply air preheater on.

A freezing danger appears, if the exhaust air temperature downstream of the heat exchanger is below +5 °C and the intake air temperature upstream of the heat exchanger is below -3 °C. After increase of the exhaust air temperature the unit reverts to the previous operation mode.

The difference between the supply and extract air flow temperature leads to condensate generation. Condensate is collected in the drain pan and is removed outside through the drain pipe. The control unit inside of the unit enables power supply and connection of the external devices.

The unit is controlled by the automatic control system (ACS), consisting of the controller and the control panel.

Depending on the model the unit includes a preheater and a reheater (DVUT P(1)BE2 EC) or only a preheater (DVUT P(1)BE EC) for warming up of the intake air flow.

The preheater prevents freezing of the heat exchanger and is located in the intake air duct before the heat exchanger. The reheater is located in the supply air duct after the heat exchanger.

The air handling unit has a possibility to connect the air quality control sensors:

- RH humidity sensor;
- CO₂ sensor;
- VOC sensor.

If the humidity level, CO₂ or VOC concentration exceed the set point (set in the user menu), the supply and extract fans automatically switch to higher speed to extract excessive humidity, CO₂ or VOC from the room.

If the humidity level, CO₂ or VOC concentration falls down below the set point, the unit reverts to the previous operation mode.

The sensors are not included in the delivery set and are to be purchased and installed by the user independently.

The movement of air in the DVUT 300 PBE2 EC unit when the bypass duct is closed

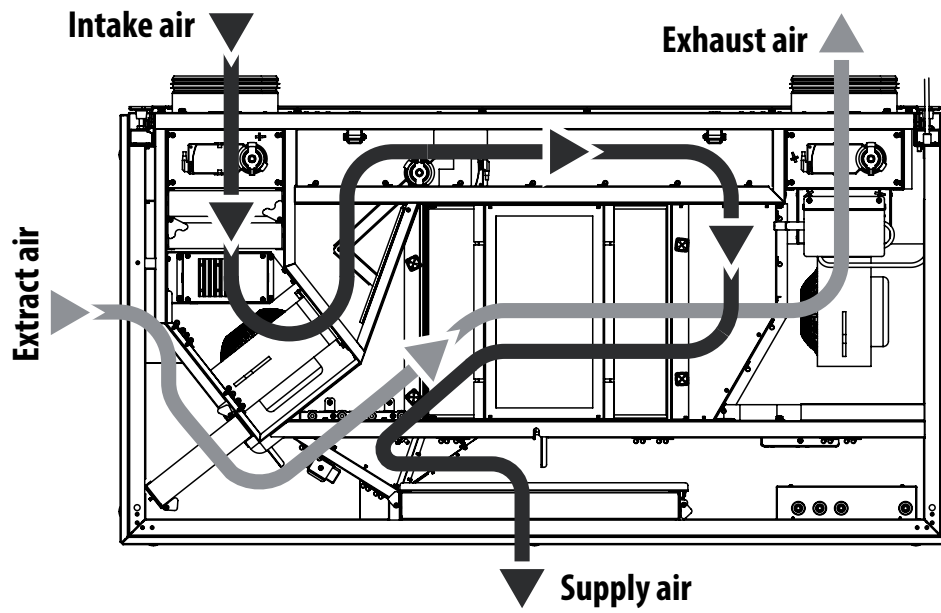

The movement of air in the DVUT 500 PBE2 EC unit when the bypass duct is open

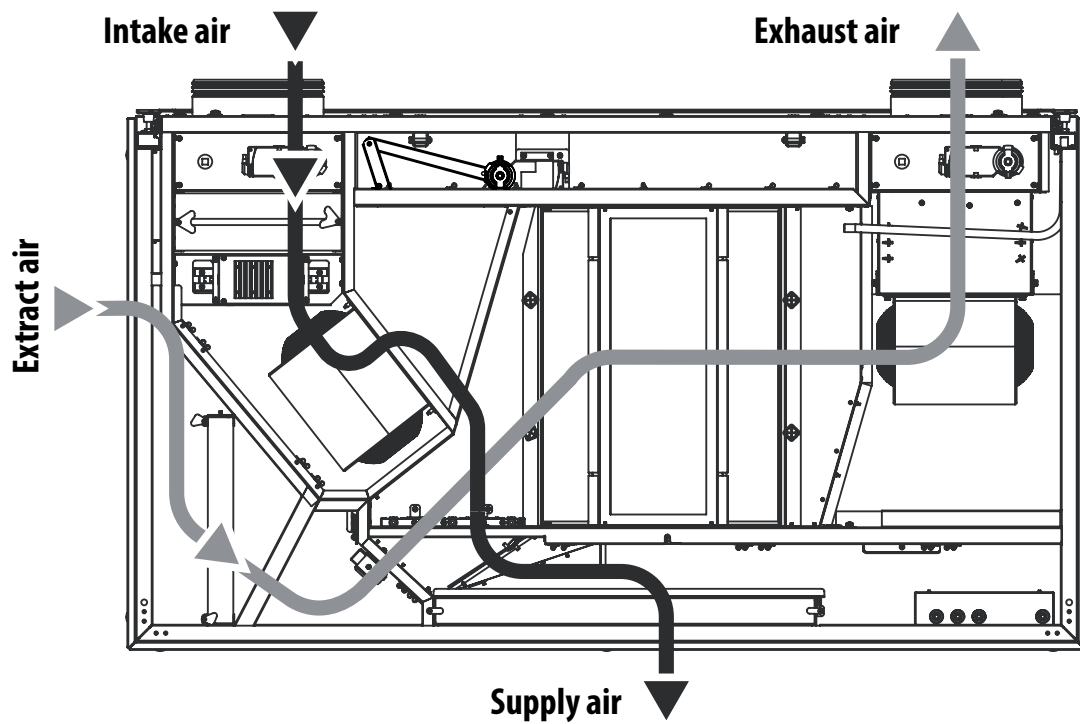

INSTALLATION AND SET-UP



WHILE INSTALLING THE UNIT ENSURE CONVENIENT ACCESS FOR SUBSEQUENT MAINTENANCE AND REPAIR.



BEFORE MOUNTING MAKE SURE THE CASING DOES NOT CONTAIN ANY FOREIGN OBJECTS (E.G. FOIL, PAPER).



THE UNIT MUST BE MOUNTED ON A PLANE SURFACE. MOUNTING OF THE UNIT TO AN UNEVEN SURFACE CAN LEAD TO THE UNIT CASING DISTORTION AND OPERATION DISTURBANCE.

ATTENTION! Route the required wires and cables to the installation place prior to starting mounting. Prior to mounting remove the transit bolts from L-brackets, by which the unit is fixed in the packing box.

Fasteners for the unit mounting are not included into delivery set and should be ordered separately. While selecting appropriate fasteners consider the material of the mounting surface as well as the weight of the unit, refer technical data. For selection of the fasteners please refer to a service technician.

The unit may be suspended on threaded rods or may be rigidly fixed to a horizontal surface by anchor bolts. The unit is suspended using the supplied mounting bracket and four L-brackets.

The vibration absorbing rubber pads must be inserted between the ceiling and the brackets.

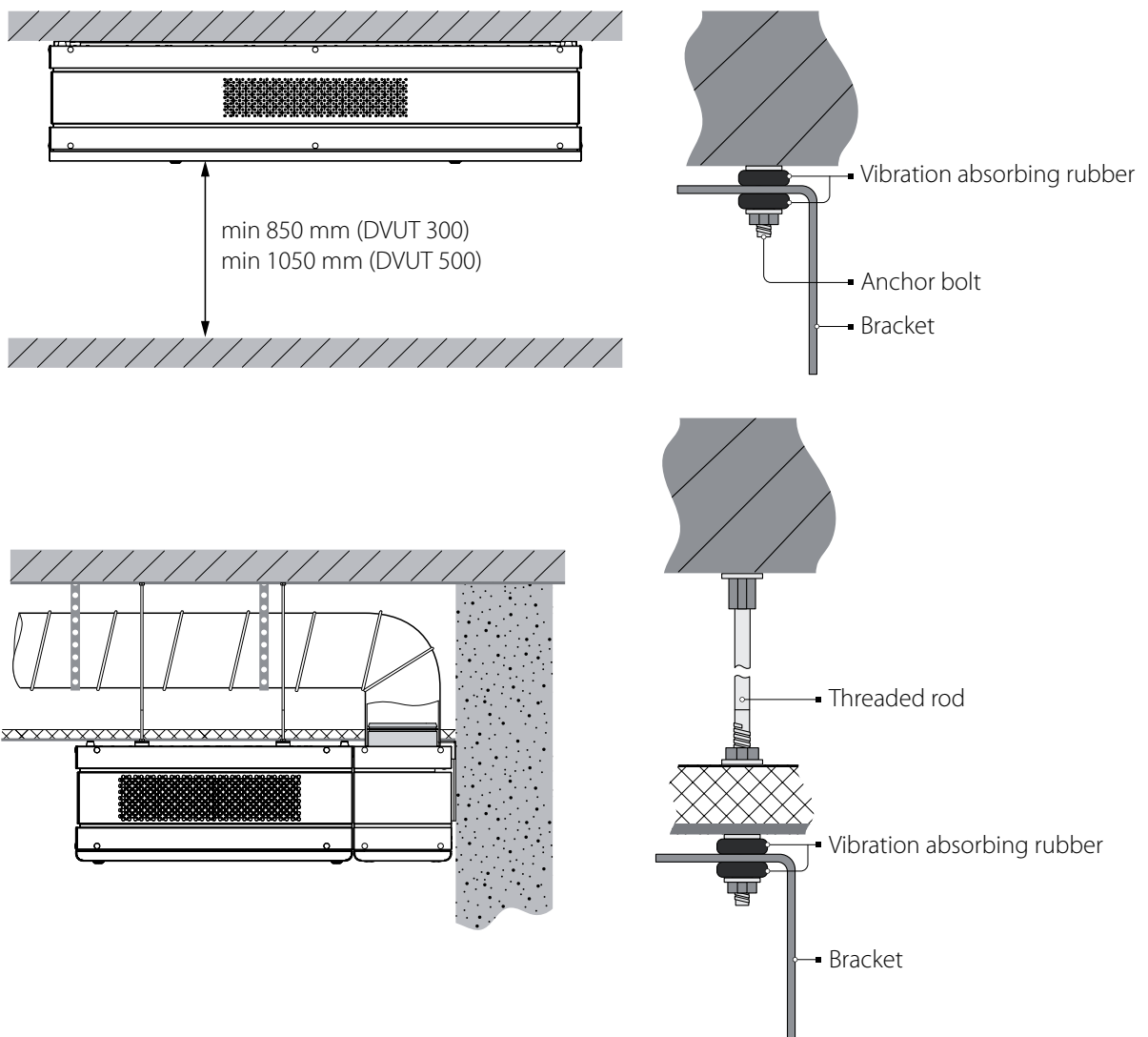

To attain the best performance of the unit and to minimize turbulence-induced air pressure losses connect straight air duct sections to the unit spigots. The minimum straight air duct length is equal to 1 air duct diameter on intake side and 3 air duct diameters on outlet side. If there are no air ducts or the air ducts are short, it is necessary to protect internal unit parts from ingress of foreign objects at one or more unit spigots. To prevent uncontrollable access to the fan the spigots may be covered with a protecting grille or other protecting device with mesh width not more than 12.5 mm.

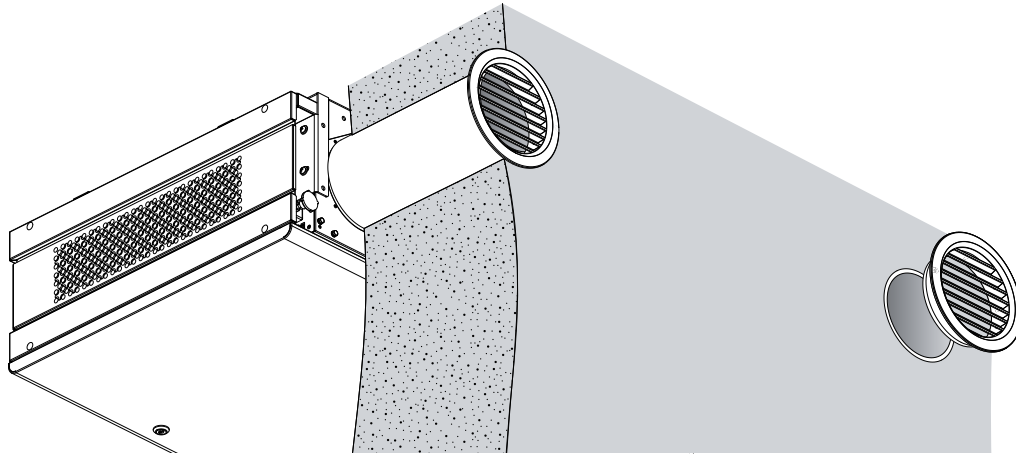

Mounting and decorative elements

Remove the decorative plugs and unscrew the screws on the side panels of the unit. Then disconnect the panels by pulling them. Unscrew the screws on the mounting bracket and four L-brackets. Remove the mounting bracket and L-brackets.

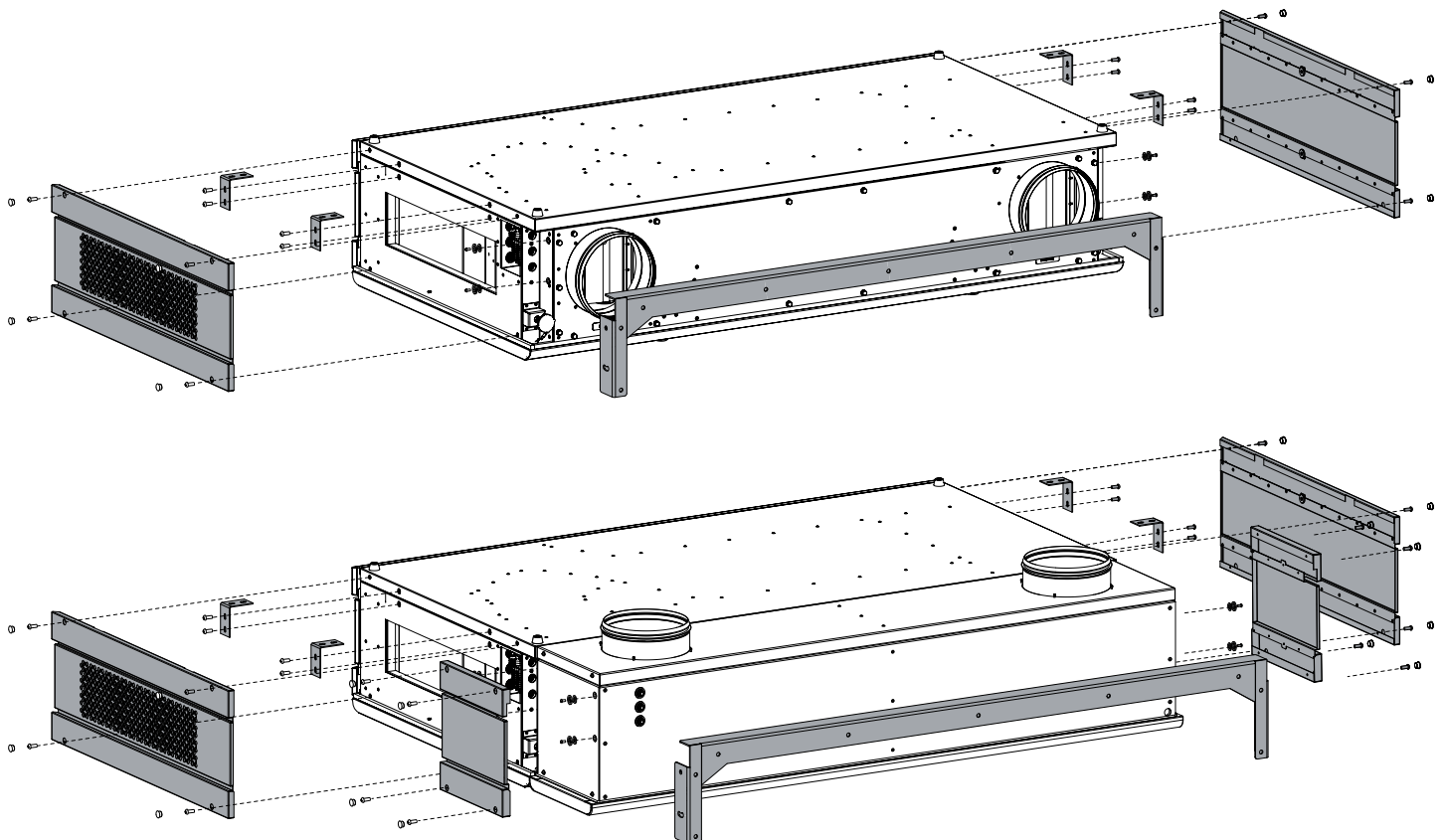

MOUNTING OF THE UNIT WITH VERTICAL SPIGOTS

Using the mounting template mark the holes on the structural floor, suspended ceiling, and wall.

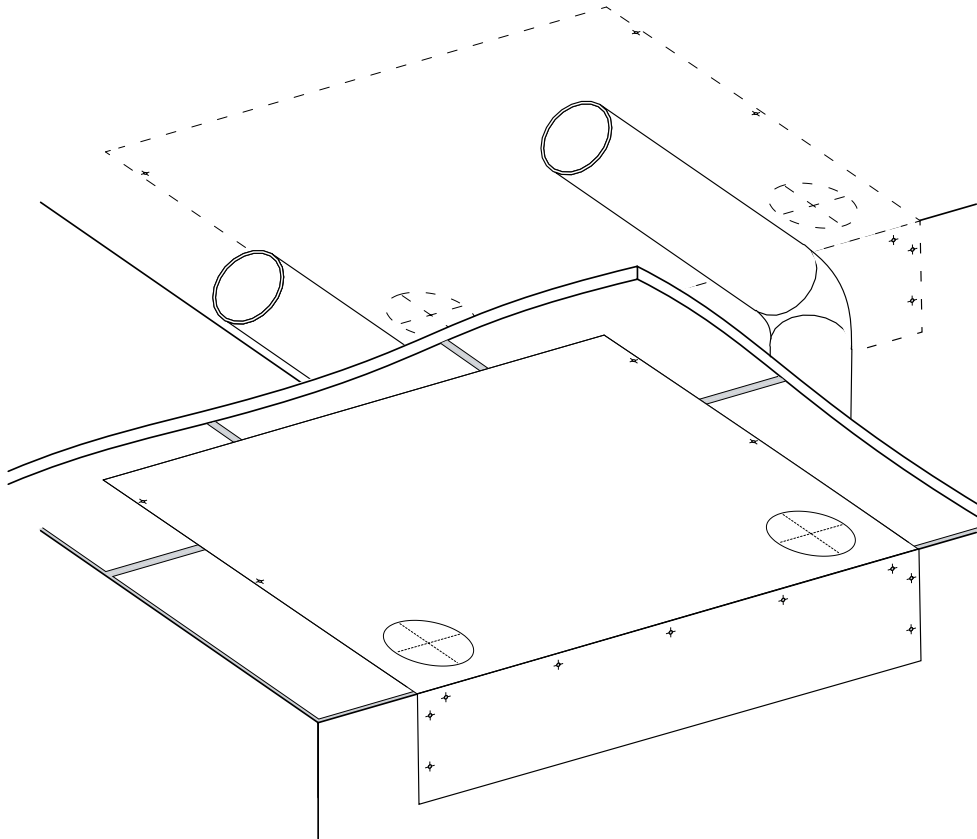

Drill the holes for L-brackets and the mounting bracket using the marking.

Prepare the holes in the suspended ceiling for connecting the air ducts: \varnothing 220 mm (for DVUT 300) or \varnothing 270 mm (for DVUT 500).

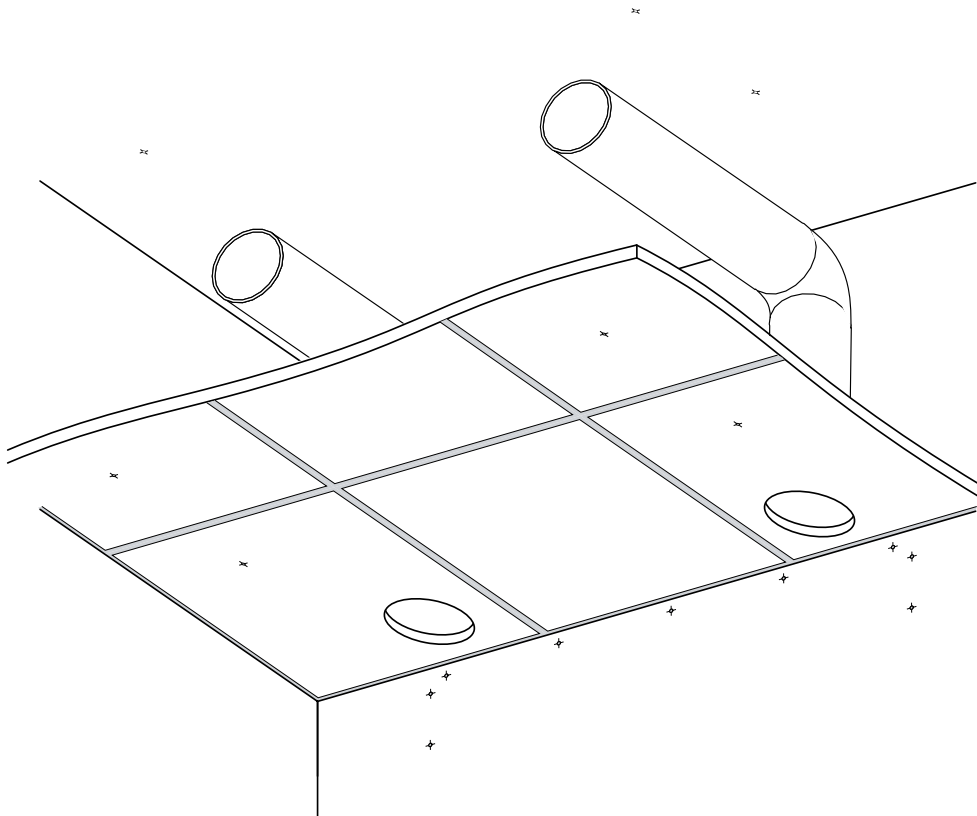

Install threaded rods in the structural floor and drill the corresponding through-holes in the suspended ceiling. Install the mounting bracket in the corner between the wall and the ceiling.

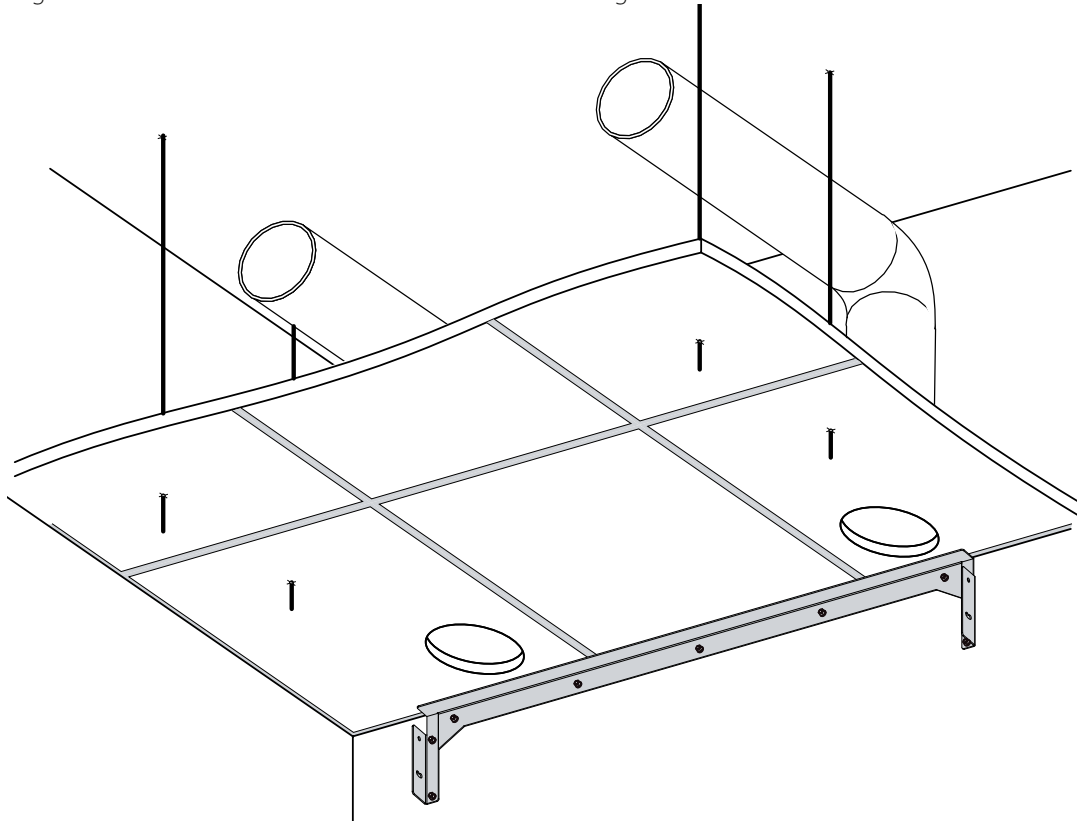

Fix the unit to the mounting bracket and L-brackets, connecting the spigots with the air ducts. Connect decorative panels and plugs.

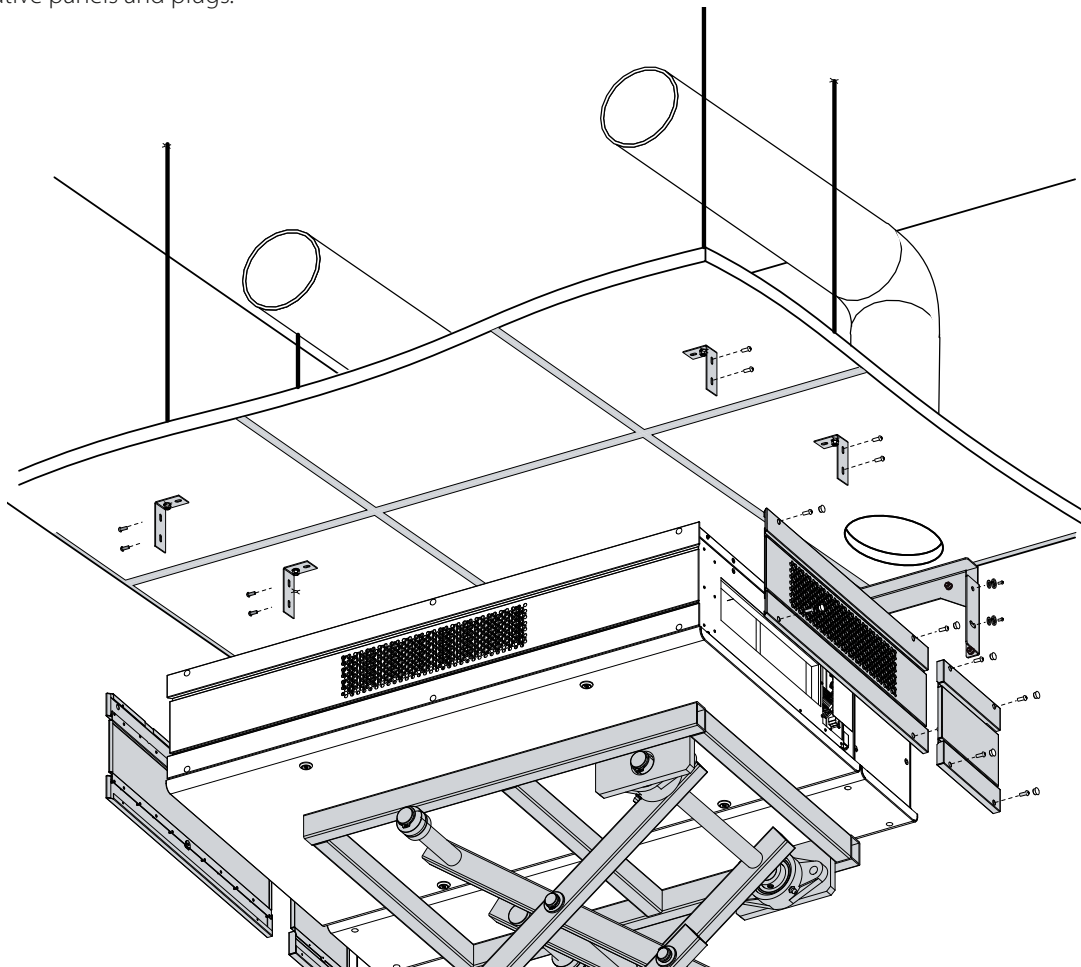

MOUNTING OF THE UNIT WITH HORIZONTAL SPIGOTS

Mark the holes using the mounting template.

Using the marking drill the holes for mounting and make through-holes in the wall for installation of the air ducts \varnothing 230 mm (DVUT 300) or \varnothing 290 mm (DVUT 500).

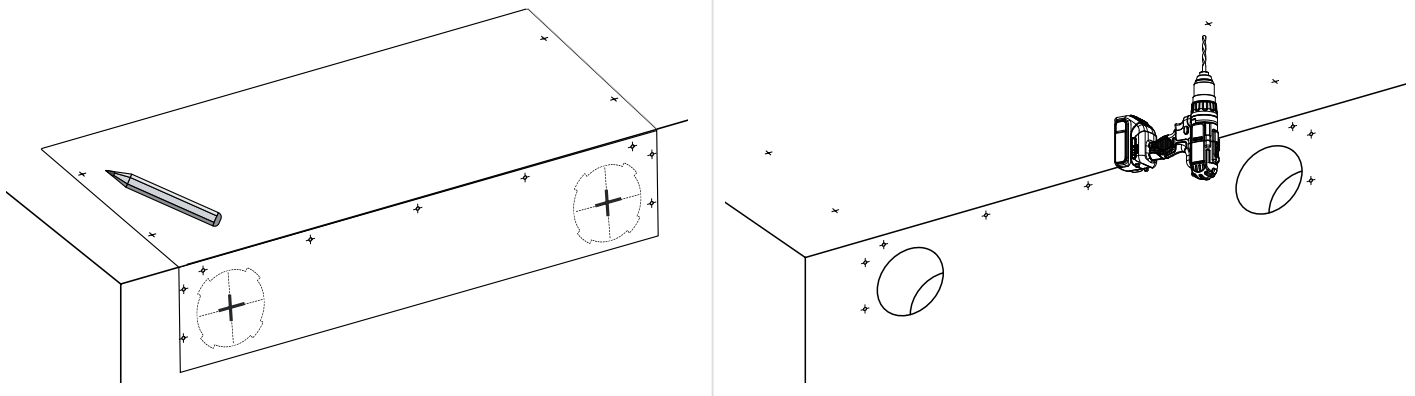

Install the air ducts in the wall (purchased separately). The air ducts must be heat-insulated for the wall freezing prevention. Insert the air ducts in the holes with the minimum slope of 3 mm downwards to the outside.

For installation use the supplied polystyrene wedges (purchased separately).

Cut the air ducts to be flush with the outer wall side to install ventilation grilles (purchased separately). The air duct length may be adjusted before its installation in the wall and after completion of mounting. In the first case the required air duct length must be calculated prior to installation and in the second case sufficient access to the outer wall must be provided for adjustment of the air duct length after it is installed and fixed.

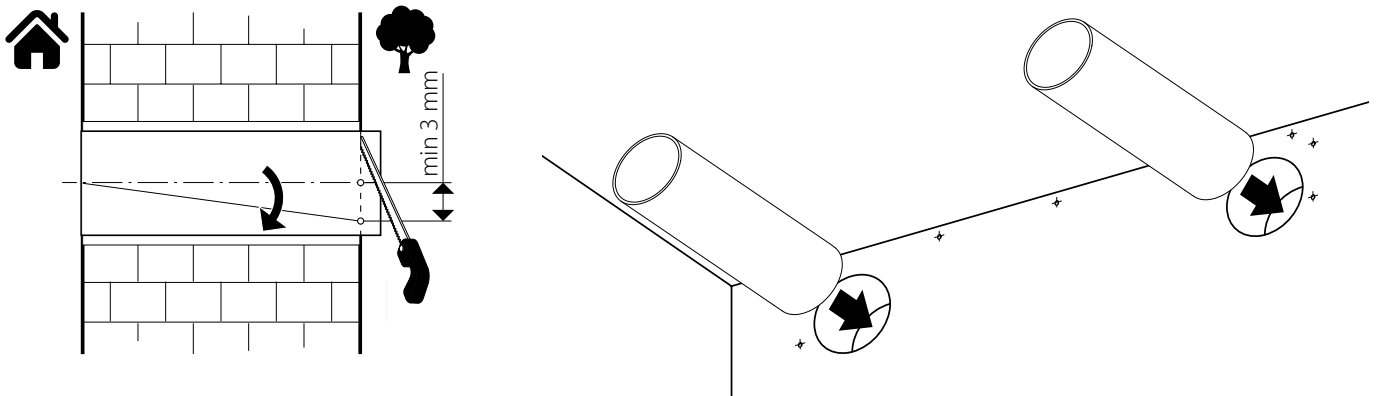

Mounting methods for units with horizontal spigots

1. By L-brackets

Opening for the unit mounting on the mounting surface

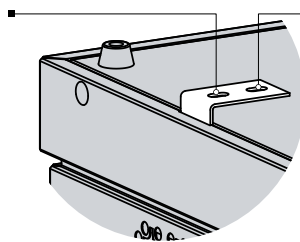

Opening for the fixation of the unit by transit bolts in the packing box

Install the brackets on the ceiling.
Connect the spigots with the air ducts in the wall and fix the unit using the L- brackets.
Connect the decorative panel and the plugs.

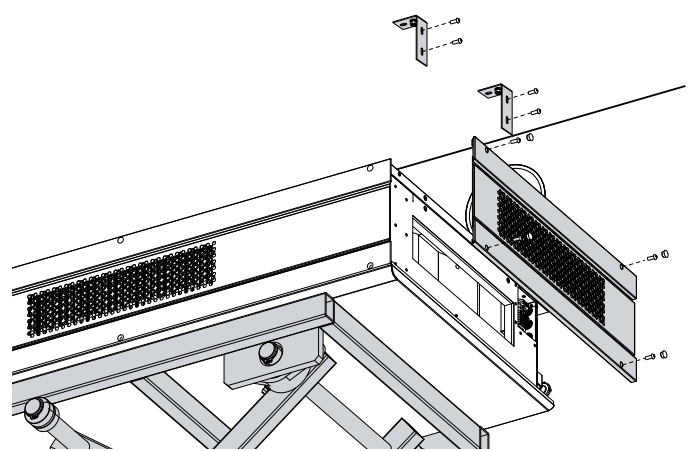
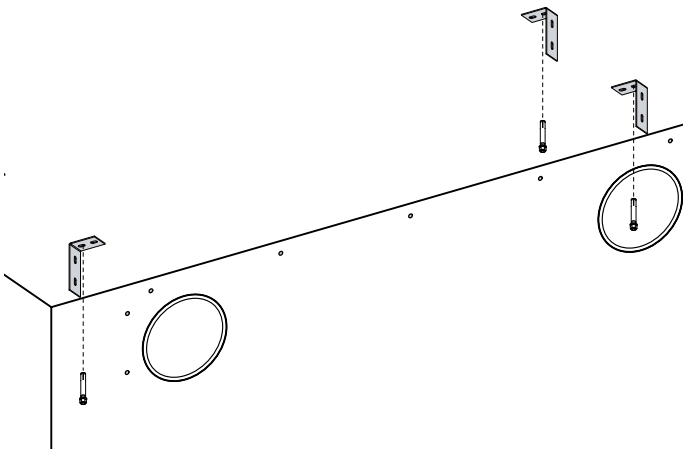

2. By the mounting bracket

Install the bracket in the wall-ceiling corner.
Connect the spigots with the air ducts and fix the unit using the mounting bracket.
Connect the decorative panel and the plugs.

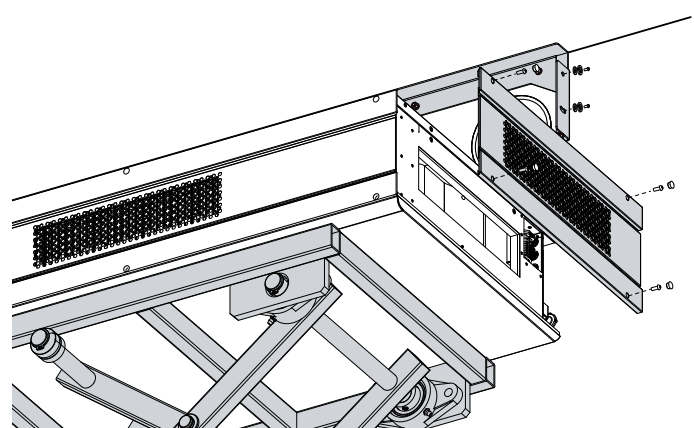
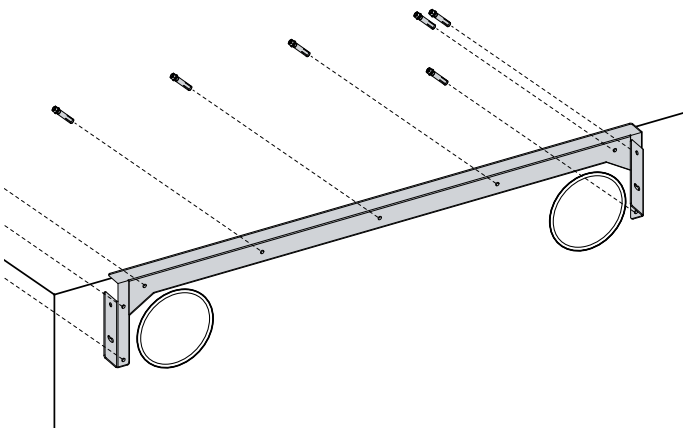

3. By the mounting bracket and L-brackets

Install the mounting bracket and L-brackets. See, p. 1, 2.
Connect the spigots with the air ducts in the wall and fix the unit using the mounting bracket and L-brackets.
Connect the decorative panel and the plugs.

Leveling of the unit with horizontal spigots

Install the unit in a horizontal position using the hand leveling screw.

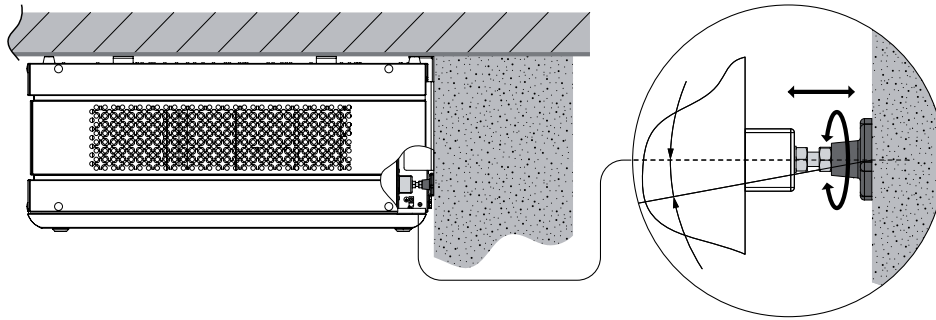

Mounting of the outer ventilation grilles

Fix the outer ventilation grilles on the outer wall. The grilles are not included in the delivery set and are available as specially ordered accessories.

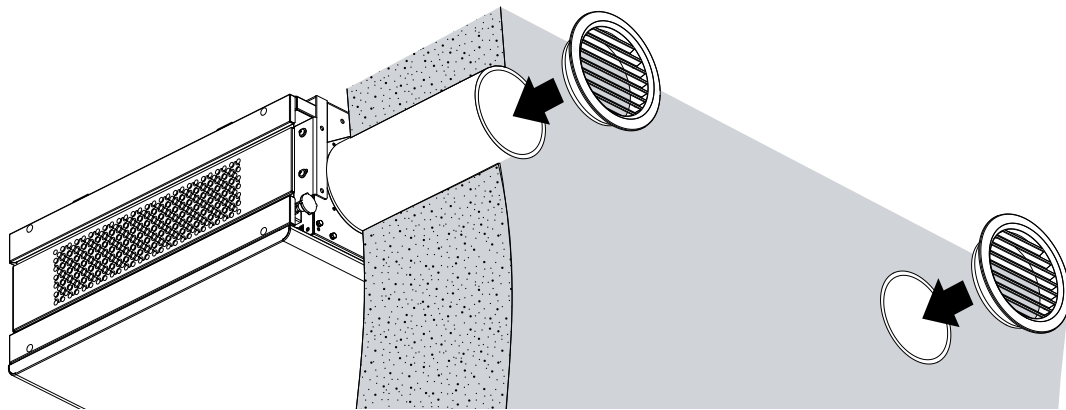

MOUNTING AND CONNECTION OF THE SENSORS: CO₂, RH, VOC

RH sensors are not included in the delivery set, purchased separately.

The sensors must be installed into the extract air duct before the heat exchanger.

Disassemble the sensor in compliance with the attached instruction.

Open the unit and connect the sensor to the control unit in compliance with the attached wiring diagram.

Assemble the sensor in the reverse order and fix it on the bracket.

Update the control configuration after connection of the sensor.

Contact the product Seller for doing that.

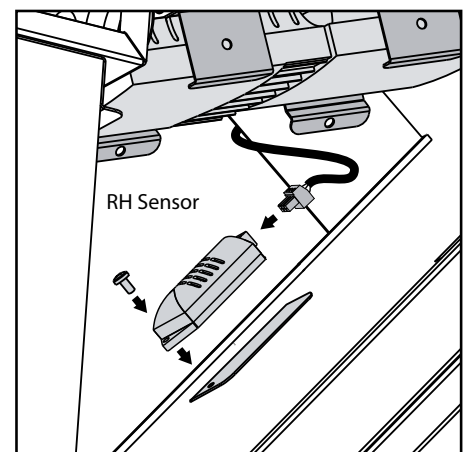
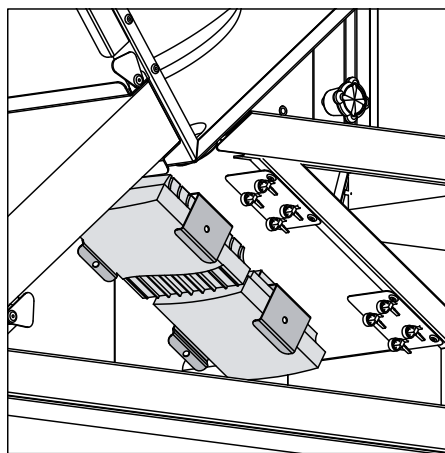
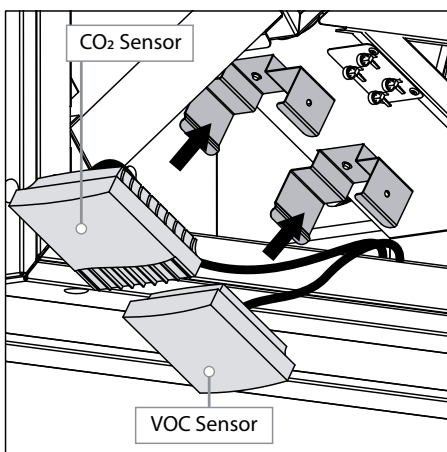

WIRING DIAGRAM FOR CONNECTION OF RH, VOC, CO₂ SENSORS TO THE CONTROL UNIT

RH sensor (DPWC112000) wiring

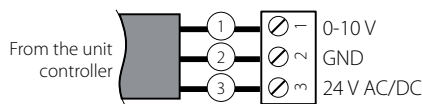

CO₂ sensor (DPWQ402000) wiring

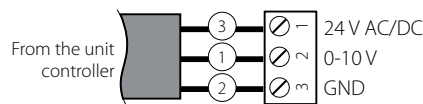

VOC sensor (DPWQ306000) wiring

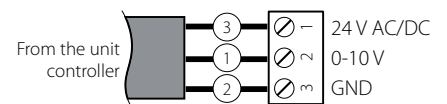

CONDENSATE DRAINAGE

For the units with a drain pump the flexible hose from the pump must be connected to the sewage system. The pump ensures timely condensate drainage from the unit.

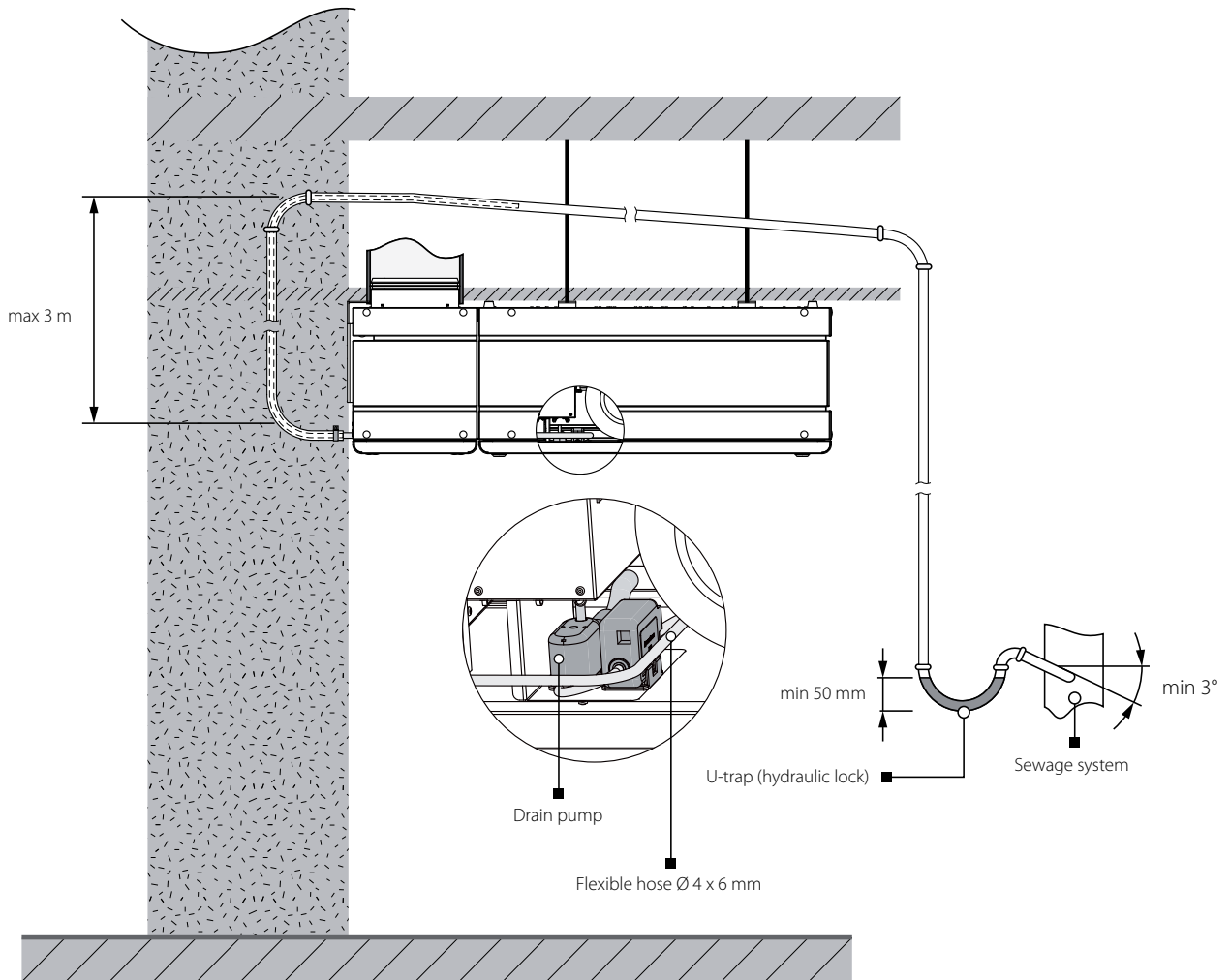

The units without a drain pump are provided with a drain pan for condensate collection and drainage outside the unit by a drain pipe. Connect the drain pipe from the unit to the sewage system. .

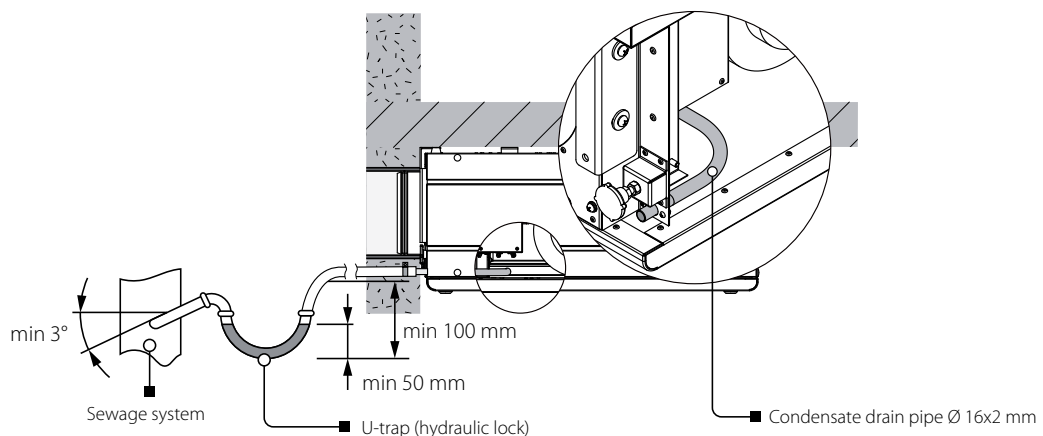

ATTENTION! Keep the minimum slope of 3° while mounting the pipes to provide correct water drainage. Before starting operation of the unit make sure that the water flows freely into the sewage collection system, otherwise condensed water may build up in the unit during the heat exchanger operation, which may cause equipment failure and water ingress into the premises. The condensate drain system is designed for use in premises with ambient temperature above 0 °C! If the expected air temperatures are below 0 °C, the condensate drainage system must be equipped with heat insulation and preheating facilities.

CONNECTION TO POWER MAINS



**POWER OFF THE POWER SUPPLY PRIOR TO ANY OPERATIONS WITH THE UNIT.
THE UNIT MUST BE CONNECTED TO POWER SUPPLY BY A QUALIFIED ELECTRICIAN.
THE RATED ELECTRICAL PARAMETERS OF THE UNIT ARE GIVEN ON THE
MANUFACTURER'S LABEL.**

- The unit is rated for connection to 1~230 V/50 (60) Hz power mains.
- The unit must be connected to power mains using insulated electric conductors (cables, wires). The actual wire cross section selection must be based on the maximum load current, maximum conductor temperature depending on the wire type, insulation, length and installation method.
- The external power input must be equipped with an automatic circuit breaker built into the stationary wiring to open the electric circuit in case of overload or short-circuit. The circuit breaker installation place must provide quick access for emergency shutdown of the unit. The trip current of the automatic circuit breaker must exceed the maximum current consumption of the unit (refer to the technical data table). The recommended trip current of the circuit breaker is the next current in the standard trip current row following the maximum current of the connected unit. The circuit breaker is not included in the delivery set.

ADDITIONAL EXTERNAL CONTROL DEVICES CONNECTION

To provide access to the place for connection of the units it is necessary to remove the side decorative panel, which hides:

- 1 ON/OFF. Set Up Mode.
- 2 Terminal block for connection of external control units according to the wiring diagram.

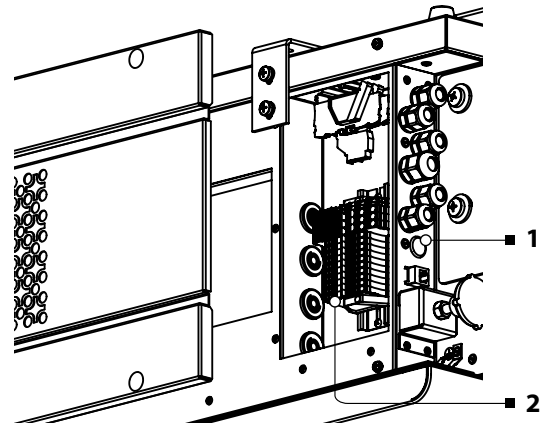

External wiring diagram
(DVUT P(1)B EC A21; A22; A25)

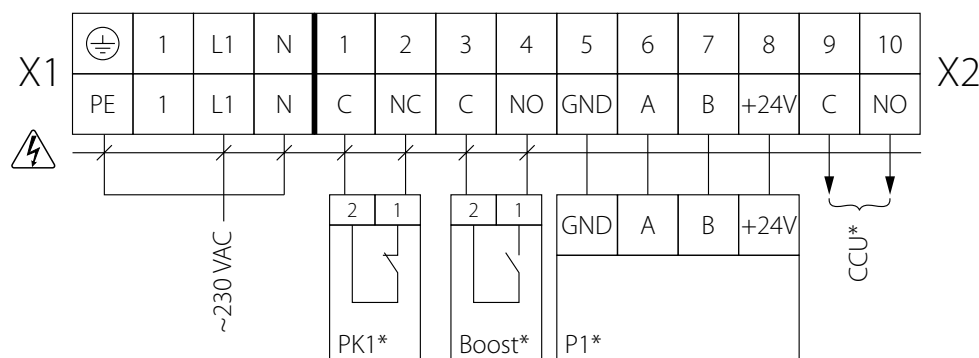

Designations	Name	Cable type	Maximum cable length	Note
CCU*	Compressor Condensing Unit	2x0,75 mm ²	20 m	3 A, 30 DC/~250 AC
PK1*	Contact from a fire alarm panel	2x0,75 mm ²	20 m	Remove the jumper during connection
P1*	Control panel A22; A25	4x0,25 mm ²	10 m	
Boost*	Contact ON/OFF, Boost mode			

*Additionally connected devices are not included in the delivery set, purchased separately.

CONTROL

The unit is controlled by:

- a wired wall control panel (A25);
- a wireless control panel (A22);
- a mobile application (A21).

Control panels can be used along with the application or separately.

Information about the panels functions and the application operation is given in the corresponding user's manuals.

TECHNICAL MAINTENANCE



DISCONNECT THE UNIT FROM POWER SUPPLY BEFORE ANY MAINTENANCE OPERATIONS!

Maintenance operations of the unit are required 3-4 times per year. Maintenance includes general cleaning of the unit and the following operations:

1. Filter maintenance.

Clogged filters increase air resistance in the system and reduce supply air volume. Clean the filters as required, but not less than 3-4 times per year. Upon elapsing of 3000 operating hours the controller reminds about the need to replace or clean the filters. In this case clean or replace the filters and reset the filter timer. Filter cleaning with a vacuum cleaner is allowed. After two consecutive cleanings the filters must be replaced. For new filters, please, contact the unit Seller.

Steps for removal of the filters:

1. Disconnect the unit from power supply.
2. Open the service door using the key.
3. Turn the latches to release the filters.
4. Pull the filters to remove.
5. After completion of maintenance install the filters in the reverse order.

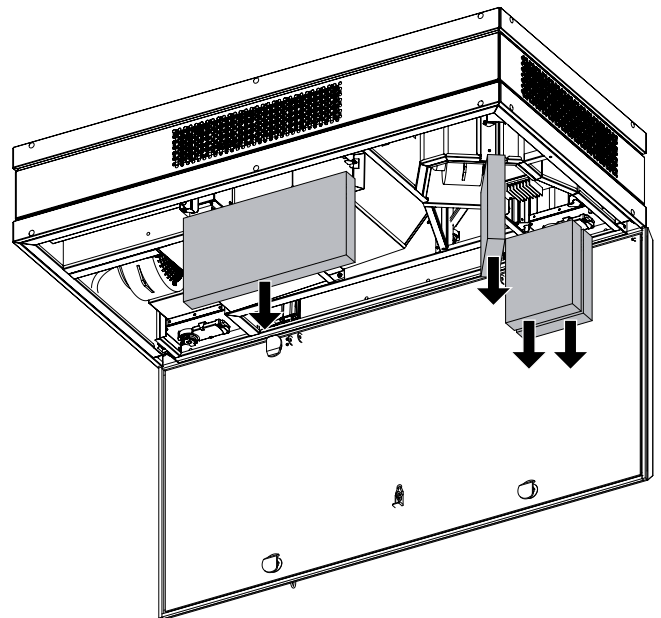
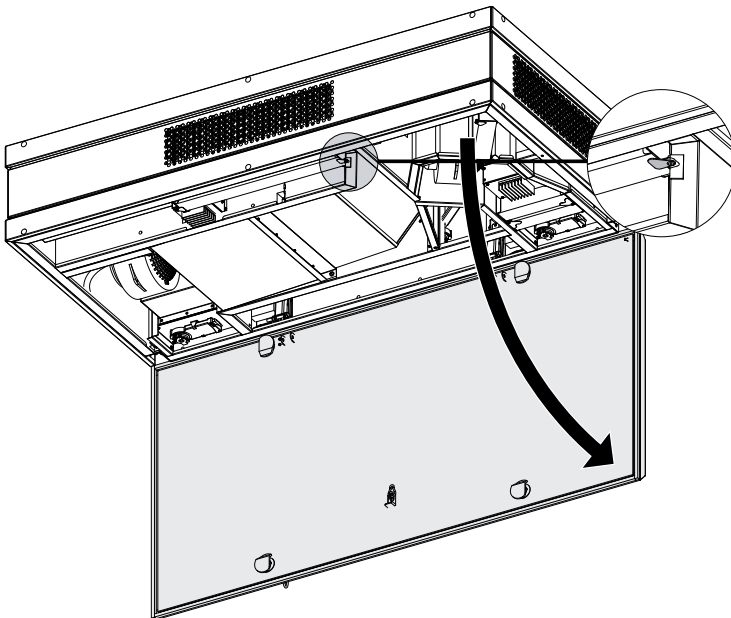

2. Heat exchanger maintenance (once per year).

Some dust may accumulate on the heat exchanger even in case of regular maintenance of the filters. Regular cleaning of the heat exchanger is required to maintain high heat recovery efficiency. To clean the heat exchanger pull it out of the unit and clean it with compressed air or a vacuum cleaner. After cleaning install the heat exchanger back in the unit.

Steps for removal of the heat exchanger:

1. Disconnect the unit from power supply.
2. Open the service door using the key.
3. Detach the hose from the drain pan.
4. Remove the screws retaining the drain pan and pull it downwards.
5. Loosen the hand screws to release the heat exchanger.
6. Pull the heat exchanger to remove.
7. After completion of maintenance install the heat exchanger in the reverse order.

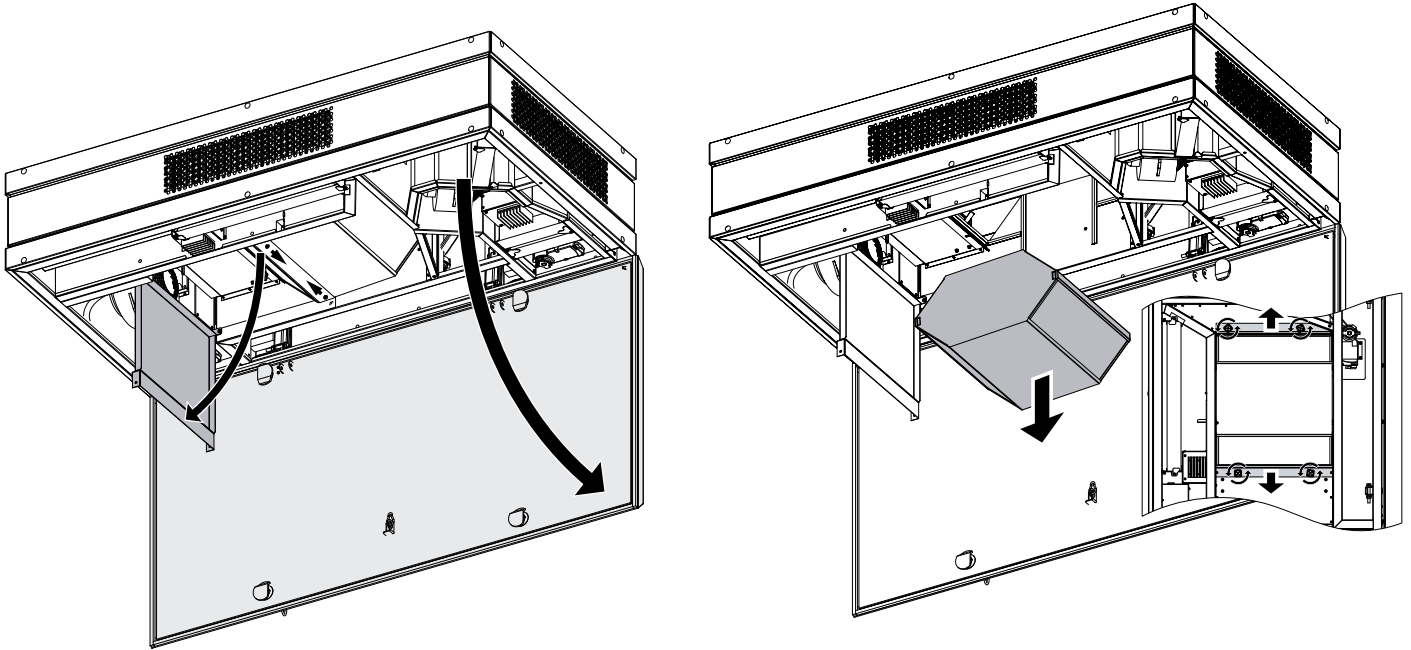

3. Fan maintenance (once a year).

Even in case of regular maintenance of the filters, some dust may accumulate inside the fans and reduce the fan performance and supply air flow.

Clean the fans with a soft cloth, brush or compressed air. Do not use water, aggressive solvents or sharp objects as they may damage the impeller.

4. Maintenance of air intake devices (twice per year).

The supply grille may get clogged with leaves and other objects, which reduces the unit performance and supply air delivery. Check the supply grille twice per year and clean it as required.

5. Air duct system maintenance (every 5 years).

Even regular fulfilling of all the maintenance operations described above may not completely prevent dust accumulation in the air ducts, which reduces the unit performance. Duct maintenance means regular cleaning or replacement.

6. Control unit maintenance (as required).

The control unit is located inside of the unit casing. For accessing the control unit remove the fixing screws on the panel and remove the control unit lid.

TROUBLESHOOTING

TROUBLE	POSSIBLE REASONS	TROUBLESHOOTING
The fan(s) do(es) not get started during activation of the unit.	No power supply.	Make sure the power supply line is connected correct. Otherwise troubleshoot a connection error.
	Motor or impeller clogging.	Turn the unit off. Troubleshoot the fan clogging. Clean the blades. Restart the unit.
	System failure. The list of the system alarms is stated in the user's manual (control panel).	Go to the active alarm page, detect a system failure and troubleshoot it. Contact the unit Seller if your efforts to troubleshoot the alarm independently fail.
Automatic circuit breaker tripping after the unit start-up.	Over-current as a result of short circuit in the electric circuit.	Turn the unit off. Contact the unit Seller.
Low air flow.	Low set fan speed.	Set higher speed.
	Clogged filters, fans or heat exchanger.	Clean or replace the filters. Clean the fans and the heat exchanger.
	Clogged or damaged air ducts, diffusers, louver shutters, grilles or other ventilation system components.	Clean or replace the air ducts, diffusers, louver shutters, grilles or other ventilation system components.
Low supply air temperature.	Clogged extract filter.	Clean or replace the extract filter.
	Contaminated heat exchanger.	Clean the heat exchanger.
Noise, vibration.	Clogged impeller or impellers.	Clean the impeller or impellers.
	Loose screw connection in the fan or in the casing.	Tighten the screws of the fans or the casing against stop.
	No anti-vibration connectors on the connection spigots.	Install the rubber anti-vibration connectors.

STORAGE AND TRANSPORTATION REGULATIONS

- Store the unit in the manufacturer's original packaging box in a dry closed ventilated premise with temperature range +5 °C...+40 °C and relative humidity up to 70 %.
- Storage environment must not contain aggressive vapors and chemical mixtures provoking corrosion, insulation, and sealing deformation.
- Use suitable hoist machinery for handling and storage operations to prevent possible damage to the unit.
- Follow the handling requirements applicable for the particular type of cargo.
- The unit can be carried in the original packaging by any mode of transport provided proper protection against precipitation and mechanical damage. The unit must be transported only in the working position.
- Avoid sharp blows, scratches, or rough handling during loading and unloading.
- Prior to the initial power-up after transportation at low temperatures, allow the unit to warm up at operating temperature for at least 3-4 hours.

MANUFACTURER'S WARRANTY

The product is in compliance with EU norms and standards on low voltage guidelines and electromagnetic compatibility. We hereby declare that the product complies with the provisions of Electromagnetic Compatibility (EMC) Directive 2014/30/EU of the European Parliament and of the Council, Low Voltage Directive (LVD) 2014/35/EU of the European Parliament and of the Council and CE-marking Council Directive 93/68/EEC. This certificate is issued following test carried out on samples of the product referred to above.

The manufacturer hereby warrants normal operation of the unit for 24 months after the retail sale date provided the user's observance of the transportation, storage, installation, and operation regulations. Should any malfunctions occur in the course of the unit operation through the Manufacturer's fault during the guaranteed period of operation, the user is entitled to get all the faults eliminated by the manufacturer by means of warranty repair at the factory free of charge. The warranty repair includes work specific to elimination of faults in the unit operation to ensure its intended use by the user within the guaranteed period of operation. The faults are eliminated by means of replacement or repair of the unit components or a specific part of such unit component.

The warranty repair does not include:

- routine technical maintenance
- unit installation/dismantling
- unit setup

To benefit from warranty repair, the user must provide the unit, the user's manual with the purchase date stamp, and the payment paperwork certifying the purchase. The unit model must comply with the one stated in the user's manual. Contact the Seller for warranty service.

The manufacturer's warranty does not apply to the following cases:

- User's failure to submit the unit with the entire delivery package as stated in the user's manual including submission with missing component parts previously dismantled by the user.
- Mismatch of the unit model and the brand name with the information stated on the unit packaging and in the user's manual.
- User's failure to ensure timely technical maintenance of the unit.
- External damage to the unit casing (excluding external modifications as required for installation) and internal components caused by the user.
- Redesign or engineering changes to the unit.
- Replacement and use of any assemblies, parts and components not approved by the manufacturer.
- Unit misuse.
- Violation of the unit installation regulations by the user.
- Violation of the unit control regulations by the user.
- Unit connection to power mains with a voltage different from the one stated in the user's manual.
- Unit breakdown due to voltage surges in power mains.
- Discretionary repair of the unit by the user.
- Unit repair by any persons without the manufacturer's authorization.
- Expiration of the unit warranty period.
- Violation of the unit transportation regulations by the user.
- Violation of the unit storage regulations by the user.
- Wrongful actions against the unit committed by third parties.
- Unit breakdown due to circumstances of insuperable force (fire, flood, earthquake, war, hostilities of any kind, blockades).
- Missing seals if provided by the user's manual.
- Failure to submit the user's manual with the unit purchase date stamp.
- Missing payment paperwork certifying the unit purchase.



FOLLOWING THE REGULATIONS STIPULATED HEREIN WILL ENSURE A LONG AND TROUBLE-FREE OPERATION OF THE UNIT.



USER'S WARRANTY CLAIMS SHALL BE SUBJECT TO REVIEW ONLY UPON PRESENTATION OF THE UNIT, THE PAYMENT DOCUMENT AND THE USER'S MANUAL WITH THE PURCHASE DATE STAMP.

CERTIFICATE OF ACCEPTANCE

Unit Type	Single-room air handling unit
Model	DVUT _____ P_B _____ EC A _____
Serial Number	
Manufacture Date	
Quality Inspector's Stamp	

SELLER INFORMATION

Seller	
Address	
Phone Number	
E-mail	
Purchase Date	
This is to certify acceptance of the complete unit delivery with the user's manual. The warranty terms are acknowledged and accepted.	
Customer's Signature	

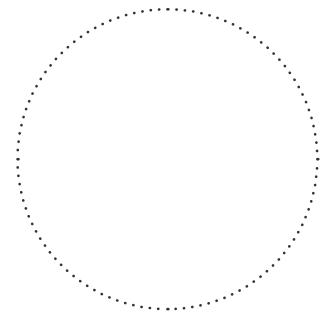

Seller's Stamp

INSTALLATION CERTIFICATE

The DVUT _____ P_B _____ EC A _____ unit is installed pursuant to the requirements stated in the present user's manual.

Company name	
Address	
Phone Number	
Installation Technician's Full Name	
Installation Date:	Signature:
The unit has been installed in accordance with the provisions of all the applicable local and national construction, electrical and technical codes and standards. The unit operates normally as intended by the manufacturer.	
Signature:	

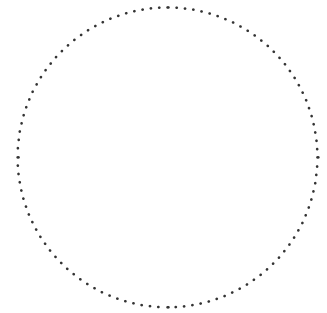

Installation Stamp

WARRANTY CARD

Unit Type	Single-room air handling unit
Model	DVUT _____ P_B _____ EC A _____
Serial Number	
Manufacture Date	
Purchase Date	
Warranty Period	
Seller	

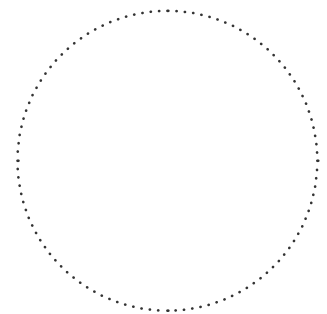

Seller's Stamp



Μιχαήλ Καραολή 19, τκ 143 43, Ν. Χαλκηδόνα, Αθήνα
Τηλ: 211 - 70.55.500 & 210 - 21.30.051, Fax: 210 - 22.23.283

