



**AIRTECHNIC**

www.airtechnic.gr

Air-Conditioning & Ventilation Components & Systems

● **ENERGY BOX**  
**TUA / TUAS**  
CEILING TYPE  
HIGH EFFICIENT HEAT RECOVERY UNIT

περισσότερα  
learn more

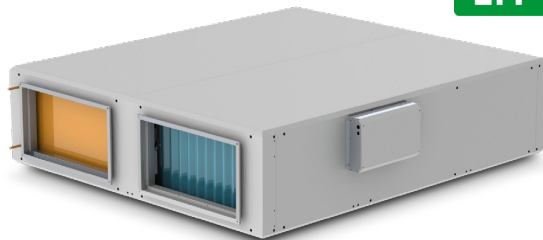

ErP 2018



 [www.airtechnic.gr](http://www.airtechnic.gr)

 [www.facebook.com/Airtechnic.gr](https://www.facebook.com/Airtechnic.gr)

 [www.instagram.com/airtechnic.chatzoudis](https://www.instagram.com/airtechnic.chatzoudis)

V. 4

# ENERGY BOX

## Index

### ENERGY BOX - TUA

**Aluminum** Counterflow Exchanger

### ENERGY BOX - TUAS (Double Skin)

**Aluminum** Counterflow Exchanger

### Ceiling Type High Efficient Heat Recovery Unit

- Unit Components	3
- Performance Data	4
- Technical Specifications	6
- Unit Dimensions	7
- Service Space & Installation	7
- Working Principle of Unit	8

### Control System

9

### Accessories

- Electric Heaters	11
- Ventilaton on Demand (VOD)	12
- Sound Attenuator	12
- Final Filter	12



### Casing & Insulation (ENERGY BOX - TUA)

High corrosion resistive 200 gr/m<sup>2</sup> galvanize coated steel is used for the casing. Inside of outdoor air side is 10 mm, outside of outdoor air side is 5 mm; inside of indoor air side is 10 mm insulated with non - flammable acoustics foam against sound and thermal conduction.

### Casing & Insulation (ENERGY BOX - TUAS)

The unit's casing is made up of **double skinned** high corrosion resistive 200 gr/m<sup>2</sup> galvanize coated steel. 30 mm thickness and 50 kg/m<sup>3</sup> density of Rockwool insulation between the walls is used for thermal and sound insulation. Non-flammable EPS modules are used for directing the air flow homogeneously. Density of EPS is 40 kg/m<sup>3</sup>.

### ENERGY BOX - TUA / TUAS

400 | 800 | 900 | 1.300 | 2.400 | 2.600 | 4.000  
 Ceiling Type High Efficient Heat Recovery Unit



### By - Pass

ENERGY BOX - TUA / TUAS units have by - pass ventilation as standard. During by-pass ventilation, no heat transfer occurs between exhaust and fresh air stream. In transition periods and at nights in summer, by-pass module helps to cool down (free-cooling) and heat up (free-heating) the building without any energy expense.

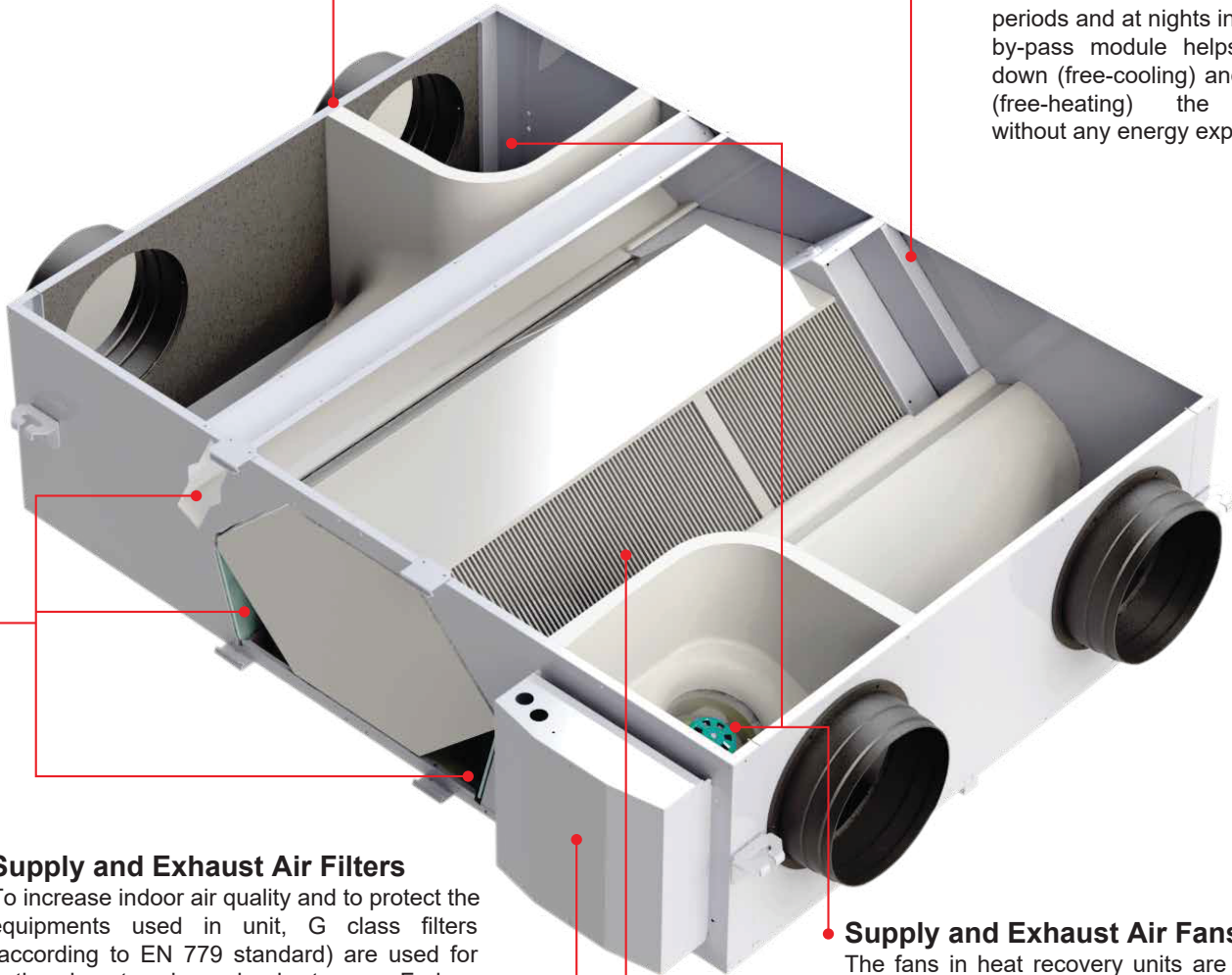

### Supply and Exhaust Air Filters

To increase indoor air quality and to protect the equipments used in unit, G class filters (according to EN 779 standard) are used for both exhaust and supply air streams. F class filters can be also used optionally in the unit. F class filters reduce the available static pressure of the unit for the nominal air flow rate.

### Control System Plug&Play

ENERGY BOX - TUA / TUAS control unit is developed for controlling of heat recovery units' equipments, meeting the demands coming from the customers and is user friendly designed. ENERGY BOX - TUA / TUAS is capable of controlling the standard equipments and optional accessories. ENERGY BOX - TUA / TUAS Control unit can perform the basic functions without any control panel; it is more functional used with Basic and Pro-Panel. Besides, the control unit can switch on/off via **BMS**, gets fault signal and controls all the functions via **ModBus**. Alternatives different from ENERGY BOX - TUA / TUAS controller are listed in "Control System" part.

### Supply and Exhaust Air Fans

The fans in heat recovery units are equipped with innovative Electronically Commutated **EC** motor technology. **EC** motors have higher efficiency and simple speed control than AC motors and connect the AC mains. Fan blades have high aerodynamic efficient backward curved design. Using the **EC** motors reduce the energy consumption and increase the energy efficiency of the unit. With **EC** Fans it is also possible to reduce maintenance costs as the fans are direct drive; free of belt and pulley.

### Heat Recovery Exchanger (Aluminum)

ENERGY BOX - TUA / TUAS heat recovery ventilation units have **aluminum Counterflow**, high efficient plate heat recovery exchangers. Plate heat recovery exchangers have plates that are produced improved surface areas to provide high efficient and leakage free design. With the optimization of exchanger heat transfer is increased and pressure drop is decreased. Heat recovery exchanger has Eurovent certification.

## Performance Data

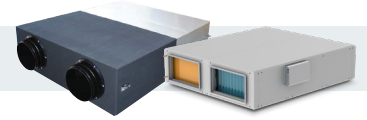

### ENERGY BOX - TUA / TUAS 400

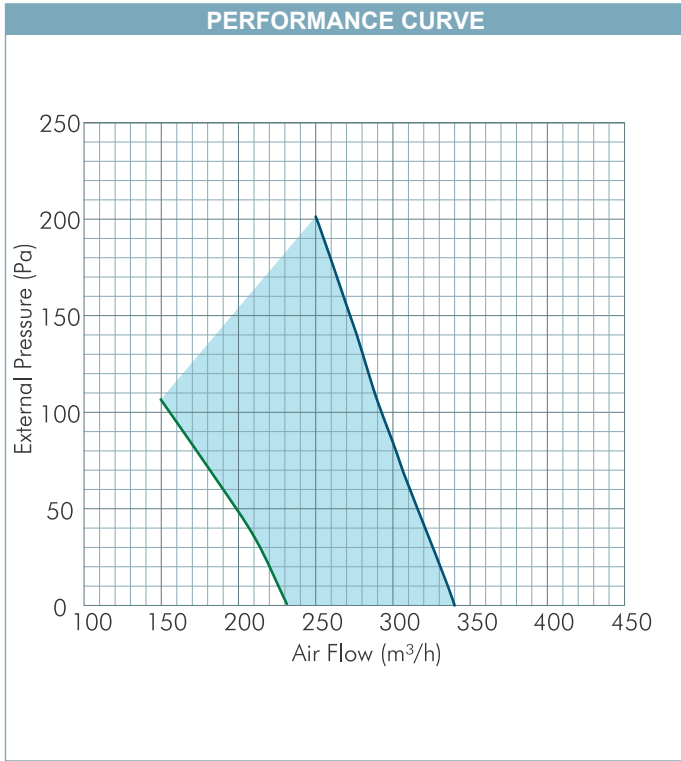

### ENERGY BOX - TUA / TUAS 800

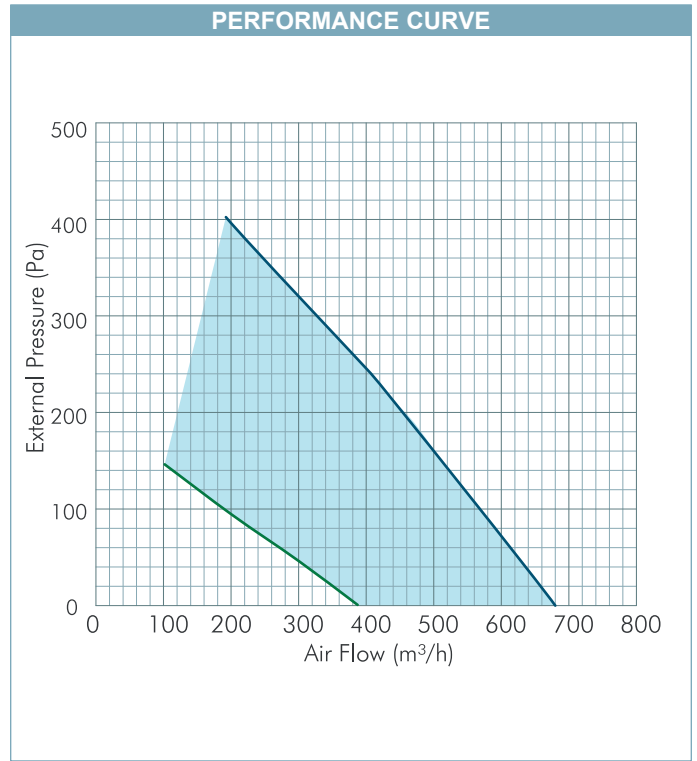

### ENERGY BOX - TUA / TUAS 900

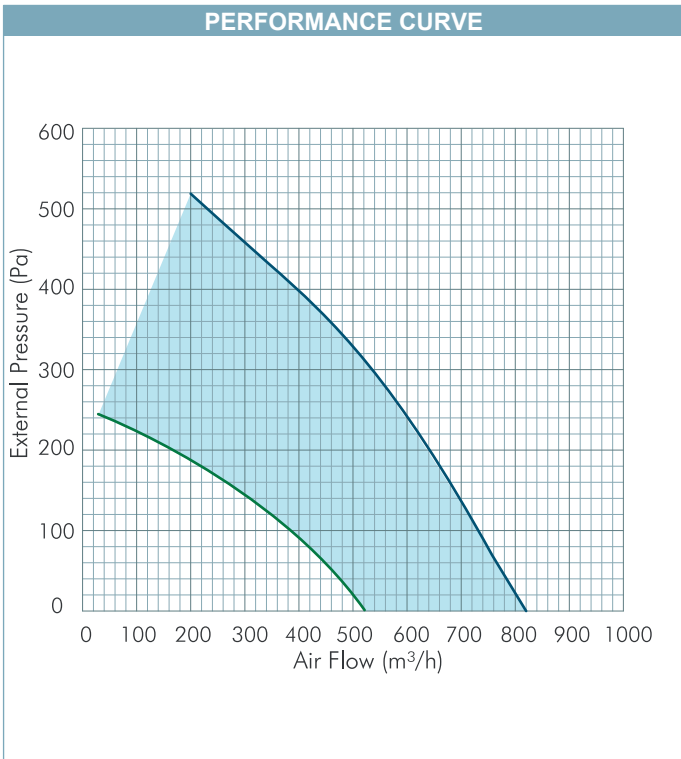

### ENERGY BOX - TUA / TUAS 1.300

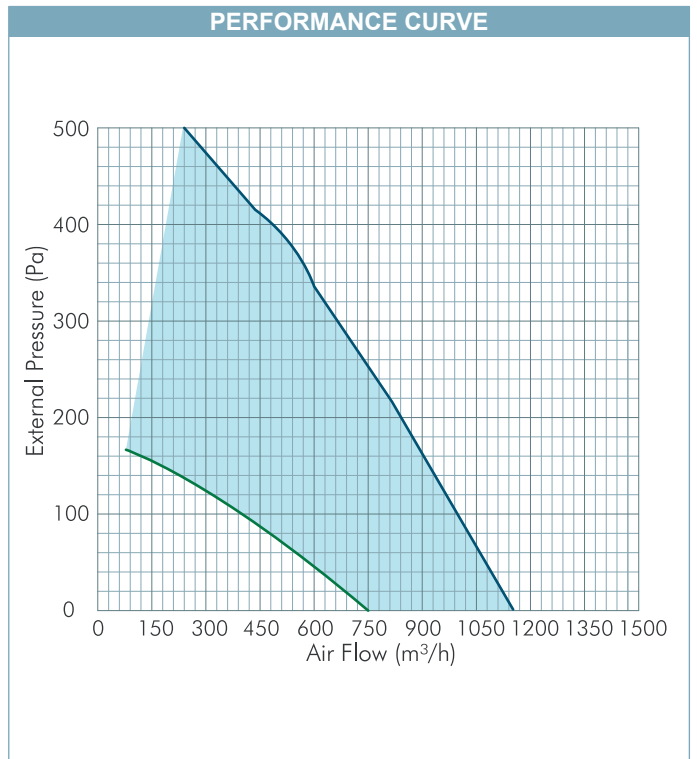



## Performance Data

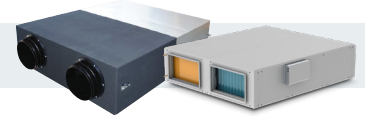

### ENERGY BOX - TUA / TUAS 2.400

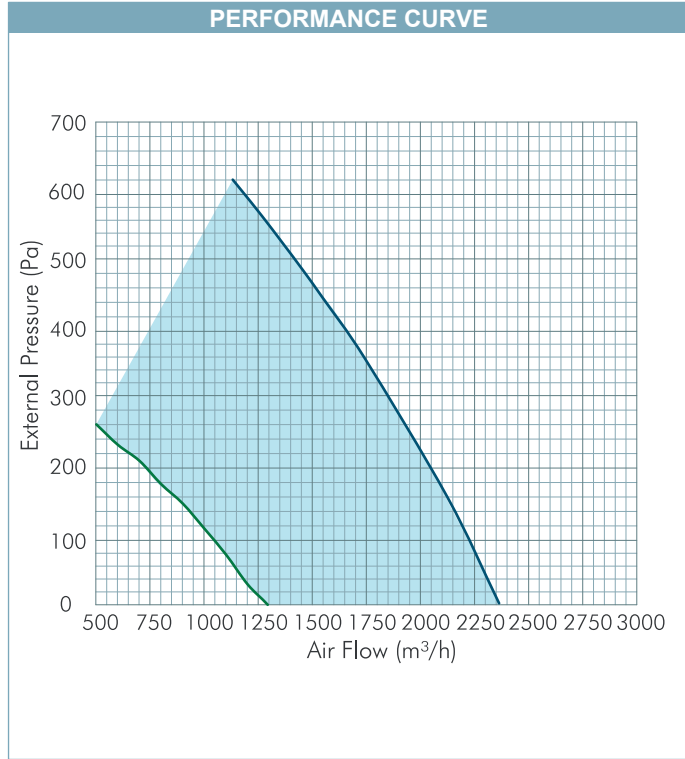

### ENERGY BOX - TUA / TUAS 2.600

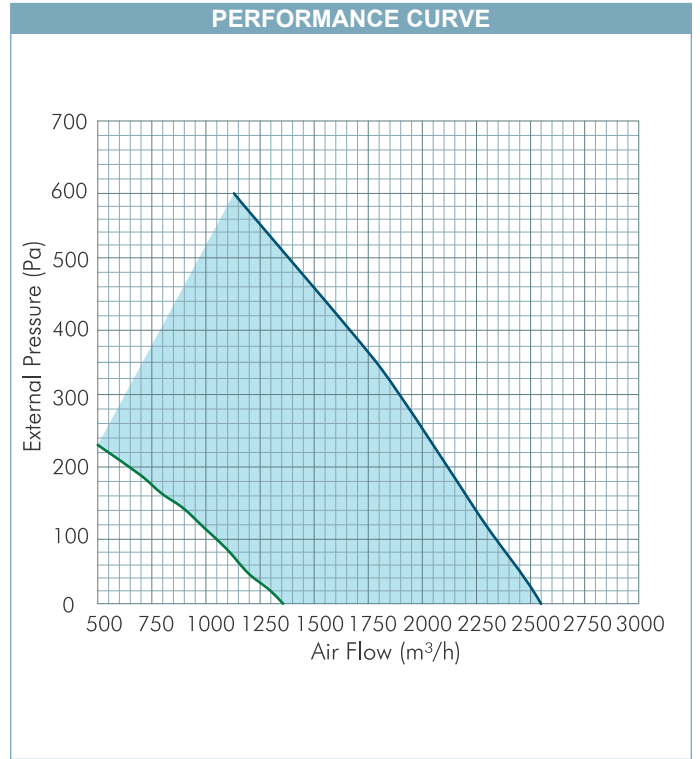

### ENERGY BOX - TUA / TUAS 4.000

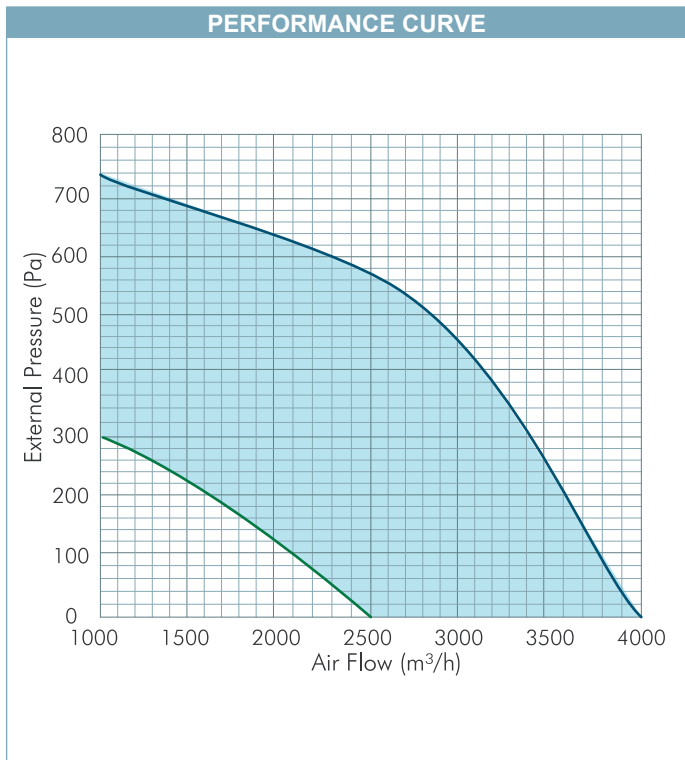

## Technical Specifications

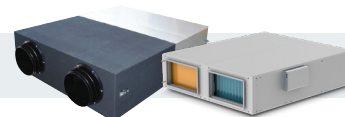

ENERGY BOX - TUA / TUAS		400	800	900	1.300	2.400	2.600	4.000
Declared typology		NRVU						
Type of drive installed or intended to be installed		variable speed drive						
Type of HRS (run around, other, none)		other						
Thermal efficiency of heat recovery <sup>1</sup>	%	<b>80,3</b>	<b>78,6</b>	<b>80,4</b>	<b>79,5</b>	<b>75</b>	<b>77,1</b>	<b>75,8</b>
Nominal flow rate	m <sup>3</sup> /h	250	490	650	975	1.400	1.650	2.750
Maximum flow rate	m <sup>3</sup> /h	<b>330</b>	<b>680</b>	<b>810</b>	<b>1.100</b>	<b>2.300</b>	<b>2.470</b>	<b>4.000</b>
Effective electric power input	W	58	144	242	277	495	678	1.100
Face velocity at design flow rate	m/s	1	1,3	1,2	1,5	1,8	1,6	1,9
Nominal external pressure ( $\Delta P_{s,ext}$ ) <sup>1</sup>	Pa	100	100	100	100	100	100	100
Internal pressure drop of ventilation components ( $\Delta P_{s,int}$ )	Pa	133	192	221	247	248	237	200
Internal pressure drop of non-ventilation components ( $\Delta P_{s,add}$ )	Pa	There is no "non-ventilation" components						
Static efficiency of fans used in accordance with Regulation (EU) No. 327/2001		39	45	50	49	57	59	59
Declared maximum external leakage rate	%	1,4	0,1	0,2	0,3	0,8	0,6	0,6
Declared maximum internal leakage rate	%	5,4	1,9	1,6	2,3	2,4	2,1	2,1
Energy classification of the filters (Energy performance)		G3						
Description of visual filter warning for NRVUs intended for use with filters <sup>2</sup>								
Sound power level (L <sub>WA</sub> ) (calculated) <sup>3</sup>		42	44	48	47	43	58	58
Internet adress for pre-/dis-assembly instructions								

Measured at balanced flow, EN 308.

Including test pointing out the importance of regular filter changes for performance and energy efficiency of the unit.

Sound power level values are valid for ENERGY BOX - TU units.

# Unit Dimensions

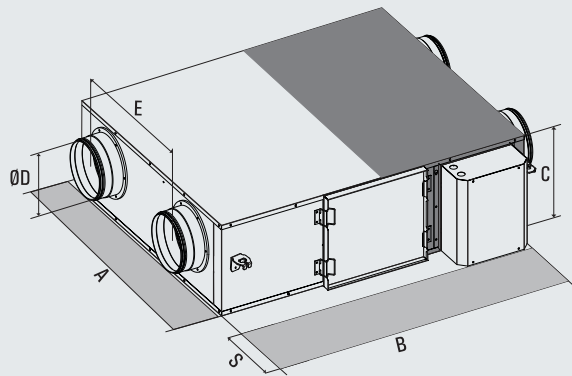
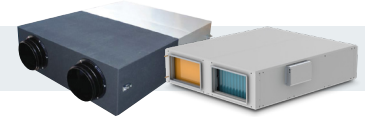

ENERGY BOX - TUAS 4.000

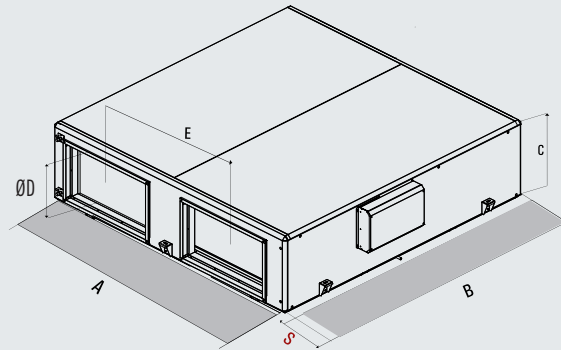

\*The gaps of the maintenance area values are specified as S (=760 mm) on the sketch.

## ENERGY BOX - TUA Unit Dimensions

	TUA 400	TUA 800	TUA 900	TUA 1.300	TUA 2.400	TUA 2.600
A	760	934	1.024	1.304	1.138	1.438
B	1.110	1.325	1.387	1.780	1.920	1.920
C	296	355	400	410	552	552
Ø D	Ø 160	Ø 200	Ø 250	Ø 300	Ø 355	Ø 355
E	404	499	589	719	623	921
Unit Weight	39	57	63	101	106	124

\*All measurement values are mm.  
\*\*Unit weight is kg.

## ENERGY BOX - TUAS Unit Dimensions

	TUAS 400	TUAS 800	TUAS 900	TUAS 1.300	TUAS 2.400	TUAS 2.600	TUAS 4.000
A	808	981	1.071	1.351	1.185	1.485	2.050
B	1.163	1.378	1.440	1.833	1.973	1.973	2.100
C	355	412	469	469	610	610	554
Ø D	Ø 160	Ø 200	Ø 250	Ø 300	Ø 355	Ø 355	700x400
E	404	500	590	720	625	920	1.030
Unit Weight	53	77	87	133	145	168	366

\*All measurement values are mm.  
\*\*Unit weight is kg.

## ENERGY BOX - TUA / TUAS Service Space & Installation

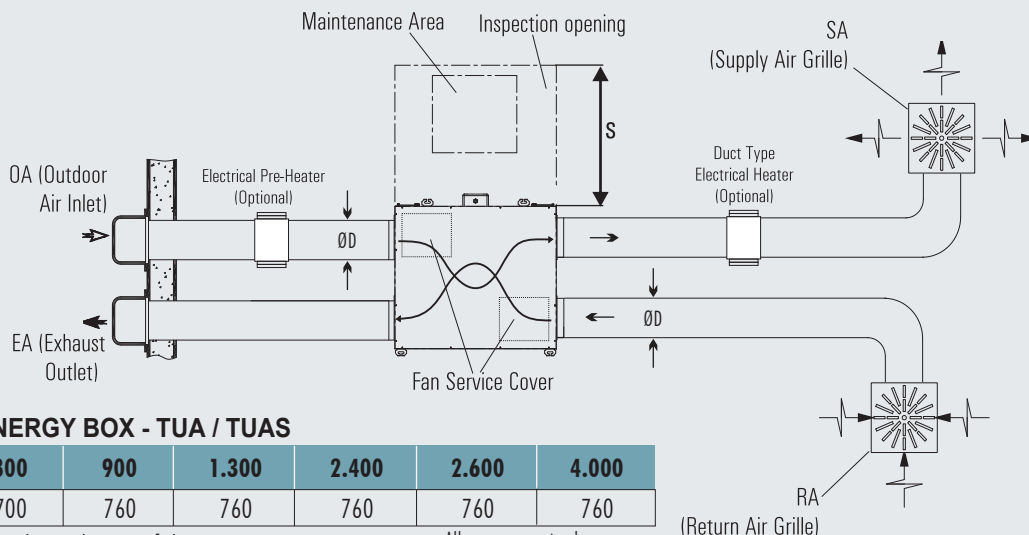

### ENERGY BOX - TUA / TUAS

	400	800	900	1.300	2.400	2.600	4.000
S	700	700	760	760	760	760	760

"S" values indicate the size of the service area.  
A service space of "C" must be left under the unit for fan service.  
Drain pipe must be installed.

All measurement values are mm.

**NOTE:** View from TOP

## Working Principle of Unit

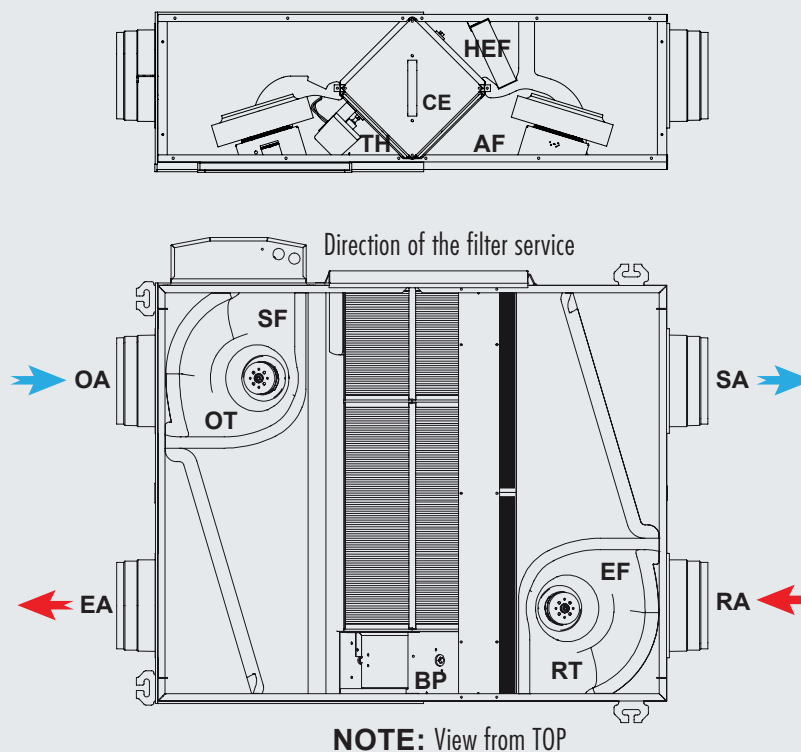
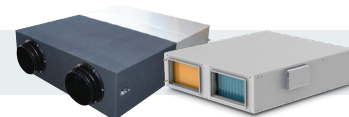

### Descriptions :

**SA - Supply Air**

**RA - Return Air**

**EA - Exhaust Air**

**OA - Outdoor Air**

**BP - By-Pass Damper**

**SF - Supply Air Fan**

**OT - Outdoor Air Temperature Sensor**

**EF - Exhaust Air Fan**

**RT - Return Air Temperature Sensor**

**AF - Exhaust Air Filter**

**CE - Aluminium Exchanger (Counter-Flow)**

**TH - Fresh Air Filter**

**HEF - High efficiency F class filter (Optional)**

## Control System

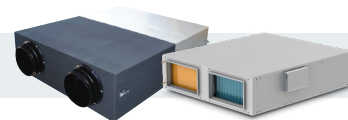

### ENERGY BOX - TUA or TUAS Series

Automation Options		Control Cards						
Standard	Optional	Standard Basic	Standard Pro	Alternative 1	Alternative 2	Alternative 3		
						Type 1	Type 2	Type 3
OA Temperature Sensor		☑	☑	☑	☑	☑	☑	☑
RA Temperature Sensor		☑	☑	☑	☑	☑	☑	☑
SA Fan Control		☑	☑	☑	☑	☑	☑	☑
RA Fan Control		☑	☑	☑	☑	☑	☑	☑
Filter Contamination Info (Time)		☑	☑	☑	☑	☑	☑	☑
Modbus RTU		☑	☑	⊗	☑	☑	☑	☑
	On/Off Damper Control	☑	☑	⊗	☑	☑	☑	☑
	Proportional Damper Control	⊗	⊗	⊗	☑	☑	☑	☑
	Airflow Control			⊗	☑		☑	
	Humidity Control	⊕	⊕	☑	☑	⊕	☑	⊕
	CO2 Control			☑	☑		☑	
	SA Temperature Sensor	☑	☑	☑	☑	☑	☑	☑
	On/Off Heating Coil	☑	☑	⊗	☑	☑	☑	☑
	Proportional Heating Coil	⊗	⊗	⊗	☑	☑	☑	☑
	On/Off Cooling Coil	☑	☑	⊗	☑	☑	☑	☑
	Proportional Cooling Coil	⊗	⊗	⊗	☑	☑	☑	☑
	Electrical Pre-Heater	☑	☑	⊗	☑	☑	☑	☑
	Electrical After-Heater	☑	☑	⊗	☑	☑	☑	☑
	BacNET MSTP	⊗	⊗	⊗	☑	☑	☑	☑
	Web Browser (TCP/IP)	⊗	⊗	⊗	☑	⊗	☑	⊗
	Weekly Timer	⊗	☑	⊗	☑	☑	☑	☑
	Filter Contamination Info (DPS)	☑	☑	☑	☑	☑	☑	☑

⊕ Only one of them the defined functions is selectable for this control card.

Control Panel		Control Cards						
Panel Type	Panel Descriptions	Standard Basic	Standard Pro	Alternative 1	Alternative 2	Alternative 3		
						Type 1	Type 2	Type 3
	Standard-Basic Wall - mounted type Max : 30 m communication ability	☑	⊗	⊗	⊗	⊗	⊗	⊗
	Standard-Pro Wall - mounted type Max : 50 m communication ability	⊗	☑	⊗	⊗	⊗	⊗	⊗
	Alternative-1 Wall - mounted type Wireless Radio Frequency (RF) panel Max : 50 m communication ability	⊗	⊗	☑	⊗	⊗	⊗	⊗
	Alternative-2 Wall - mounted type hand panel, IP 30 protection class, Max : 100 m communication ability	⊗	⊗	⊗	☑	⊗	⊗	⊗
	Alternative-3.1 Wall - mounted type room panel, IP 30 protection class, Max : 700 m communication ability	⊗	⊗	⊗	⊗	⊗	⊗	☑
	Alternative-3.2 <b>Hand Panel 1:</b> Wall - mounted type, IP 65 protection class for only front side of panel, Max:50 m communication ability <b>Hand Panel 2:</b> Magnet type, IP 65 protection class for whole panel, Max : 50 m communication ability	⊗	⊗	⊗	⊗	☑	☑	☑
	Alternative-3.3 Magnet type, IP 31 protection class, Max : 700 m communication ability	⊗	⊗	⊗	⊗	☑	☑	☑

## Control System

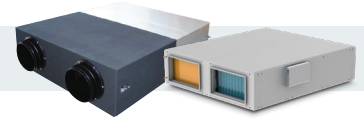

### ■ Selection of Electrical Cable Cross - Section

Unit Model TUA / TUAS	Unit Voltage (V)	Unit Power Input (kW)	Current (A)	Fuse (A)	Cable Cross - Section (mm <sup>2</sup> ) for 50m and PF = 0,8
<b>400</b>	230	0,09	1	1	1,5
<b>800</b>	230	0,21	1	2	1,5
<b>900</b>	230	0,29	2	2	1,5
<b>1.300</b>	230	0,30	2	2	1,5
<b>2.400</b>	230	1	6	10	1,5
<b>2.600</b>	230	1	6	10	1,5
<b>4.000</b>	380	2,2	3,4	3x6	1,5

### ■ Cable Cross-Section Formulas

**1**

$$I_{\text{current}} = \frac{P}{U \cdot \cos Q}$$

$$I_{\text{cable}} > I_{\text{current}}$$

**2**

$$\%e = \frac{100 \cdot P \cdot L}{k \cdot S \cdot U^2}, \quad S = \frac{100 \cdot P \cdot L}{k \cdot \%e \cdot U^2}$$

$$\%e = \%3$$

**3**

$$I_{\text{cable}} > I_{\text{fuse}} \geq I_{\text{current}}$$

$$\text{Cable Cross-Section } S = \text{Max } (S1, S2, S3, 1.5\text{mm}^2)$$

**P** : Power

**I** : Current

**U** : Voltage

**S** : Conductor cross section

**k** : Conductor coefficient

**L** : Conductor length

**%e** : The voltage drop

### ■ Example of Cable Cross-Section Calculation

**P** : 1 kW

**L** : 50 m

**U** : 230V

**%e** : %3

**PF** : CosQ : 0,8

**k** : 56 m /Ω

**1**

$$I_{\text{current}} = \frac{1000 \text{ W}}{230 \cdot 0,8} = 5,43 \text{ A}$$

The cable will be used, is selected from the cable cross-section table so that the equivalent ampere value in the table should be higher than calculated "I<sub>current</sub>" value.

$$S1 = 1,5 \text{ mm}^2$$

**2**

$$\%e = \%3$$

$$S = \frac{100 \cdot 1000 \cdot 50}{56 \cdot 3 \cdot 230^2} = 0,56 \text{ mm}^2$$

$$S2 \geq 0,56 \text{ mm}^2 \geq 0,75 \text{ mm}^2$$

$$S2 = 0,75 \text{ mm}^2$$

**3**

$$I_{\text{cable}} > I_{\text{fuse}} \geq I_{\text{current}}$$

$$I_{\text{cable}} > 10\text{A} \geq 5,43\text{A}$$

"I<sub>fuse</sub>" which will be higher than "I<sub>current</sub>", is selected.

The cable will be used, is selected from the cable cross-section table so that the equivalent ampere value in the table should be higher than selected "I<sub>fuse</sub>" value.

$$I_{\text{cable}} = 24\text{A}$$

$$S3 = 1,5 \text{ mm}^2$$

$$\text{Cable cross-section } S = \text{Max } (S1, S2, S3, 1,5 \text{ mm}^2)$$

$$S = \text{Max } (1,5, 0,75, 1,5, 1,5)$$

$$S = 1,5 \text{ mm}^2$$



## Accessories

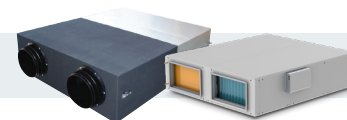

### ■ Electric Heaters



Electric heaters are optionally supplied in cold climates for supply air and in extreme climates for both supply and outdoor air sides against freezing. Electric heaters are manufactured according to circular or rectangular duct systems. Standard types are produced of stainless steel heating elements and galvanized metal casing. Stainless steel casing is also available.

Electric heaters capacity can be controlled up to 2 steps with control panel according to the set temperature from the room control panel and room (or supply air) temperature. Speed controls shall not be used with Electric heater installations. electric heaters are connected in Delta connection in standard models.

### Heating Capacity Calculation

$$Q = 0,33 \times V \times (T_2 - T_1)$$

Q : Heating Capacity (W)

V : Air Flow through electric heater (m<sup>3</sup>/h)

T<sub>1</sub> : Air temperature before the heater (°C)

T<sub>2</sub> : Air temperature after the heater (°C)

### Electrical Heater Capacity

Unit Model ENERGY BOX		Heater Diameter (mm)	Capacity (Pre-Heater) (kW) (Outdoor air between 0°C and -5°C)	Capacity (Pre-Heater) (kW) (Outdoor air between -5°C and -15°C)	Capacity (After-Heater) (kW) (Heating the supply air to 25°C)
TUA / TUAS	400	160	1	1,5	1
	800	200	1	3	2
	900	250	1,5	4,5	3
	1.300	300	2	6	4
	2.400	355	4	10	6
	2.600	355	4	12	8

## Accessories

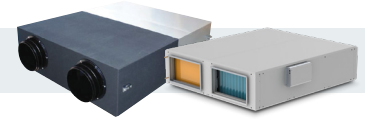

### ■ Ventilation on Demand

Air Quality Sensor is mounted to the return air duct and is connected to control system of unit. The set point for the desired indoor air quality is set during the installation. According to the demand indoors, ENERGY BOX units are modulated automatically by the sensor. Annual energy consumption of the unit is reduced as a result of the modulation, ending in reduction in energy costs.

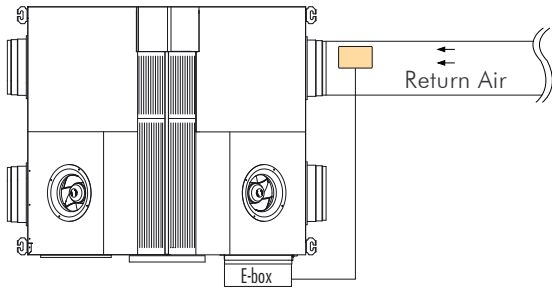

Fresh air demand in a space is calculated according to human occupancy and/or physical properties of the conditioned space. The calculation is based on the maximum indoor occupancy. In practice maximum occupancy is observed for only a small period of time annually where lower air flow rates will be sufficient for most of the year. By reducing the air flow rate according to the fresh air demand;

It is possible to reduce units electrical consumption and reduce also energy consumption used to condition the space. It should be noted that by increasing fresh air rate, indoors heating/cooling demand will also be increased. With the help of control kit of unit, it is possible to regulate fresh air rate according to the demand indoors. Indoor air quality sensor or CO2 sensor is mounted to the return duct or the conditioned space and the demanded condition is set. A 0-10 V signal will be created and ENERGY BOX unit's air flow will be regulated according to the signal.

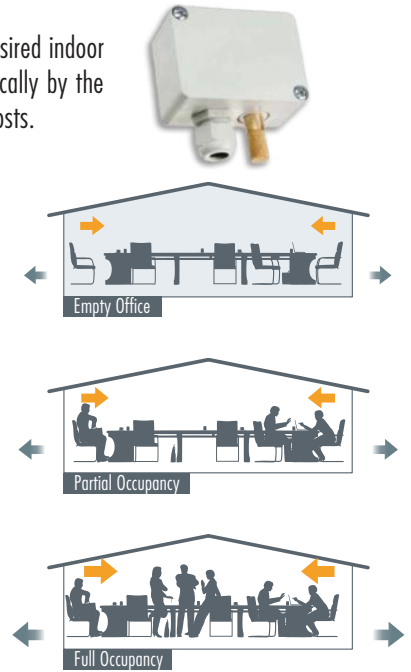

### ■ Sound Attenuator For Circular Ducts

Sound attenuators are designed for standard duct dimensions. Various lengths are available according to attenuation demand. Sound attenuation capacities are given in the table. For better performance sound attenuators can be used in series. For the best result the sound attenuators shall be installed just after the unit.



Sound Attenuation Capacity [dB]									Sound Attenuator Dimensions [mm]		
SLT	63	125	250	500	1k	2k	4k	8k	length (L)	Ø di	Ø do
200 -300	1	2	3	6	10	14	12	14	300	200	260
200 -600	2	3	6	7	13	17	18	20	600	200	260
200 -900	3	4	7	10	16	18	21	22	900	200	260
250 -300	1	2	6	6	13	16	14	15	300	250	310
250 -600	2	3	7	7	18	21	20	22	600	250	310
250 -900	3	4	9	8	21	24	21	23	900	250	310
300 -300	1	2	4	4	10	12	12	15	300	300	360
300 -600	1	3	6	7	13	15	17	19	600	300	360
300 -900	2	4	7	8	15	17	18	21	900	300	360
355 -600	1	3	8	8	9	6	5	7	600	355	415
355 -900	4	4	13	13	11	7	6	8	900	355	415

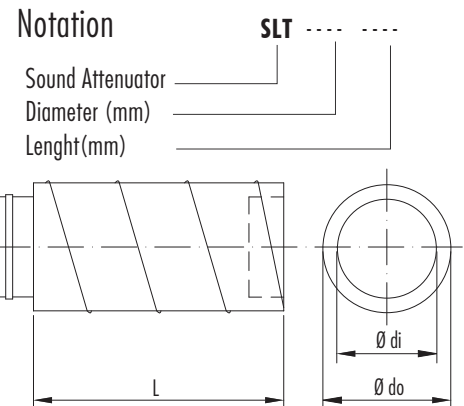

### ■ Final Filter (F Class - Optional)



F class filters are optionally available for ENERGY BOX units. Additional pressure drop due to final filters are indicated on the diagrams. To reduce initial and operational pressure drop innovative pleated type filters are used to increase filtration surface. Units' maximum air flow is reduced due to filter pressure drop.



Management System  
ISO 14001:2015  
Valid until:  
2024-09-24



www.tuv.com  
ID: 9108650718

ISO 9001:2015

ISO 14001:2015

### AIR HANDLING UNITS



### HEAT EXCHANGERS



### FAN COIL UNITS



### FANS & FAN SECTIONS



### FIRE DAMPERS



### AIR OUTLETS



### STEAM HUMIDIFIERS - DEHUMIDIFIERS



### CENTRAL VACUUM SYSTEMS



**TUBO**  
THINK CLEAN

### STAINLESS STEEL CHIMNEYS



### AIR FILTERS



### AIR CURTAINS



### EVAPORATIVE COOLING



#### Main Office ATHENS

📍 Paparrigopoulou 10 & Lagada,  
12132, Peristeri, Athens

211 - 705.55.00

✉ sales@airtechnic.gr

#### Factory - THIVA

📍 4<sup>th</sup> km Thiva - Chalkida Hwy,  
32200, Thiva

22620 - 89.006

✉ factory@airtechnic.gr

#### Factory - THESSALONIKI

📍 End of Meandrou Str.,  
57013, Oraiokastro, Thessaloniki

2311 - 82.40.00

✉ thessaloniki@airtechnic.gr