



**AIRTECHNIC**

www.airtechnic.gr

Air-Conditioning & Ventilation Components & Systems

# ● Energy Box TO

CEILING TYPE ENERGY RECOVERY UNIT



100 ÷ 5.735  
m<sup>3</sup>/h

 [www.airtechnic.gr](http://www.airtechnic.gr)

 [www.facebook.com/Airtechnic.gr](https://www.facebook.com/Airtechnic.gr)

 [www.instagram.com/airtechnic.chatzoudis](https://www.instagram.com/airtechnic.chatzoudis)

V. 4



## Index

Unit Components	2
Performance Data	3
Technical Specifications	8
Unit Dimensions	8
Service Space & Installation	8
Control System	9
<b>Accessories</b>	
Duct Type Electric Heaters	12
Duct Type Coils	12
Ventilation on Demand	12
Sound Attenuator For Circular Ducts	12

### Casing & Insulation

High corrosion resistive 200 gr/m Galvanize coated steel is used for the casing. The unit is insulated from inside with 10 mm polyether foam against sound and thermal conduction.

### Aluminum Cross - flow Heat Exchanger

ENERGY BOX - TO heat recovery ventilation units have **aluminum crossflow**, plate heat recovery exchangers. Plate heat recovery exchangers have plates that are produced improved surface areas to provide high efficient and leakage free design. With the optimization of exchanger heat transfer is increased and pressure drop is decreased. Heat recovery exchanger has Eurovent certification.

### Control System Plug&Play

ENERGY BOX - TO control unit is developed for controlling of heat recovery units' equipments, meeting the demands coming from the customers and is user friendly designed. ENERGY BOX - TO is capable of controlling the standard equipments and optional accessories. ENERGY BOX - TO Control unit can perform the basic functions. Besides, the control unit can be switched on/off via **BMS**, gets fault signals and controls all the functions via **ModBus**. Alternative controllers are listed in "Control System" part.

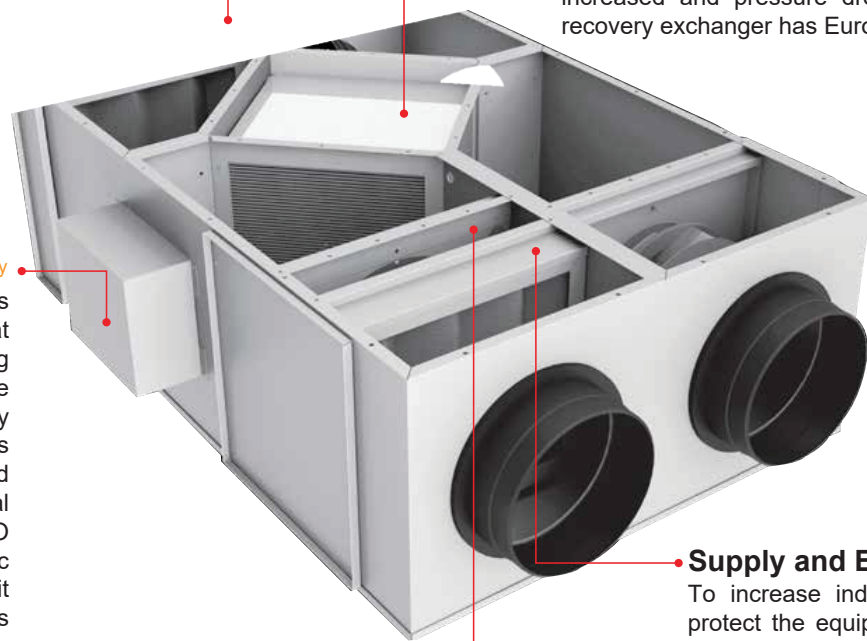

### Supply and Exhaust Air Fans

Backward curved plug fans are used in ENERGY BOX - TO units. Fan blades have high aerodynamic efficient backward curved design. Plug fans are used for high efficiency and low sound levels. With AC Fans, maintenance costs are reduced as the fans are directly connected to the motors; the belt and pulley problems are eliminated.

### Supply and Exhaust Air Filters

To increase indoor air quality and to protect the equipments used in unit, G class filters (according to EN 779 standard) are used for both exhaust and supply air streams. F class filters can be also used optionally. F class filters reduce the available static pressure of the unit for the nominal air flow rate.



## Performance Data

### ENERGY BOX - TO 350

PERFORMANCE CURVE

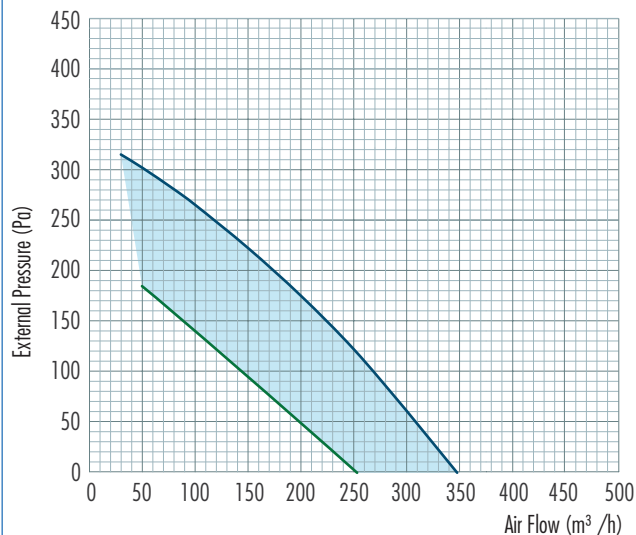

### ENERGY BOX - TO 800

PERFORMANCE CURVE

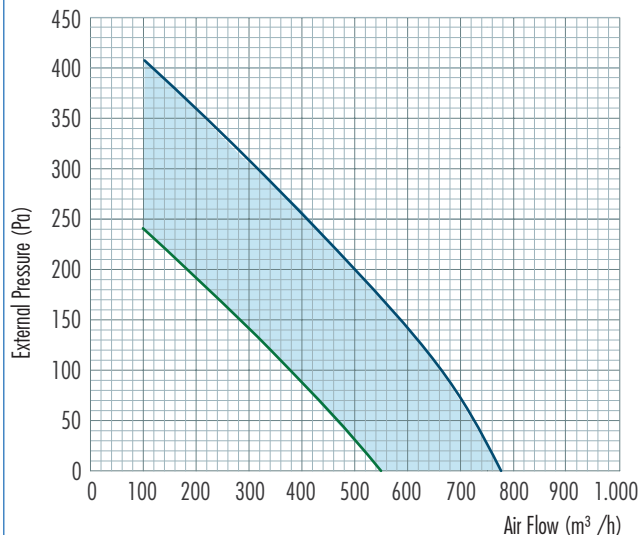

### ENERGY BOX - TO 350

SOUND CURVE

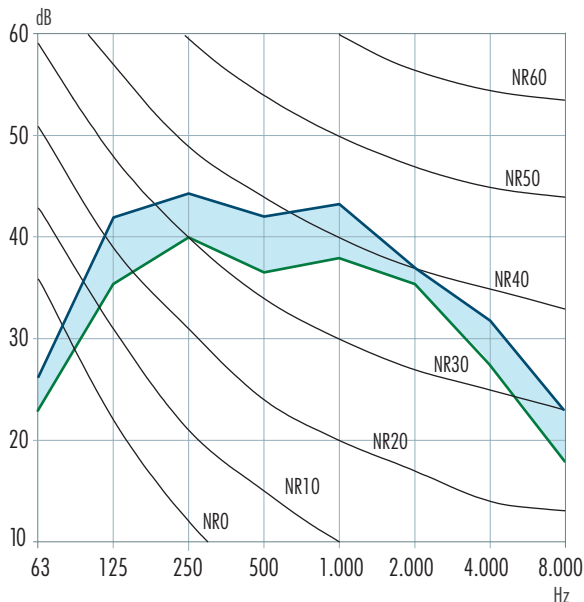

### ENERGY BOX - TO 800

SOUND CURVE

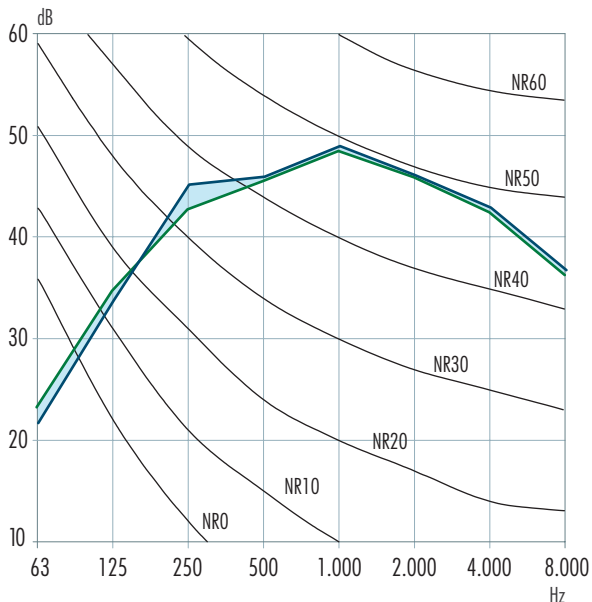



## Performance Data

### ENERGY BOX - TO 900

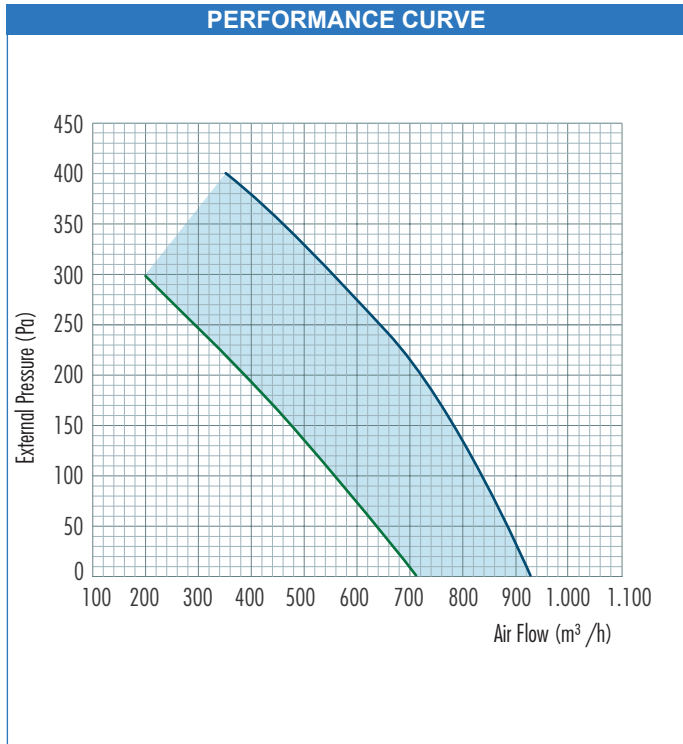

### ENERGY BOX - TO 1.400

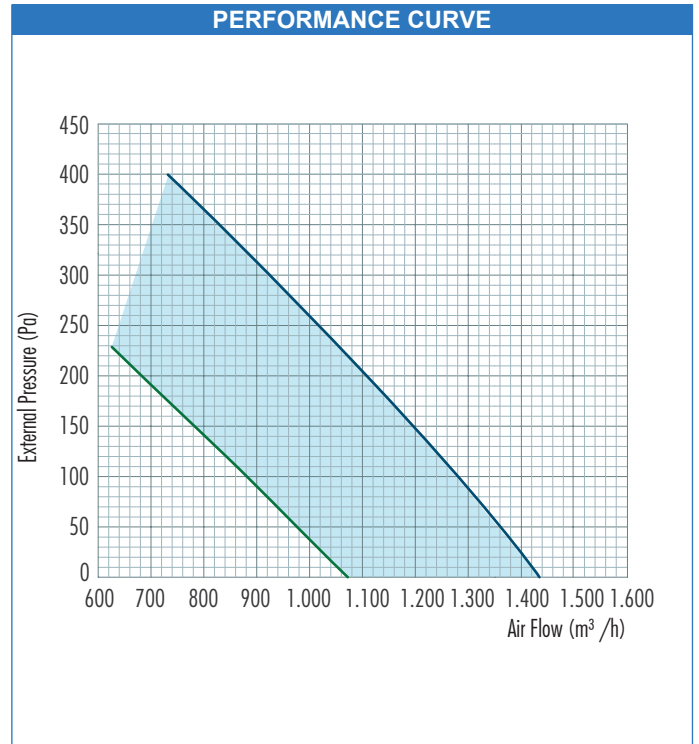

### ENERGY BOX - TO 900

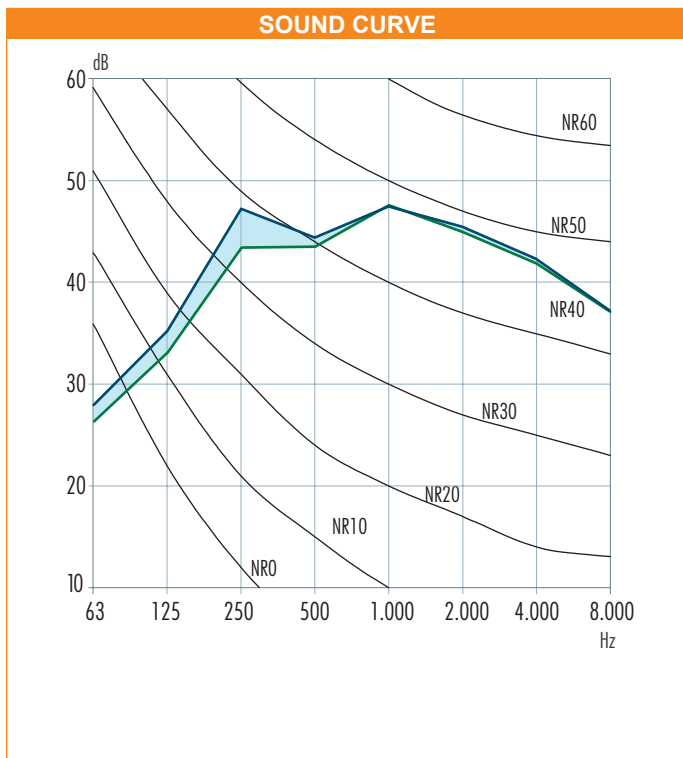

### ENERGY BOX - TO 1.400

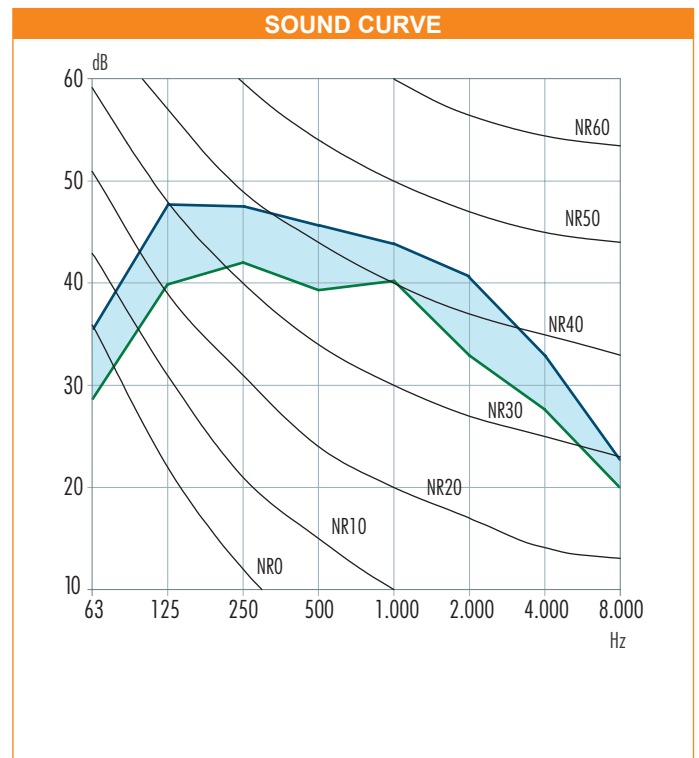



# Performance Data

## ENERGY BOX - TO 1.800

PERFORMANCE CURVE

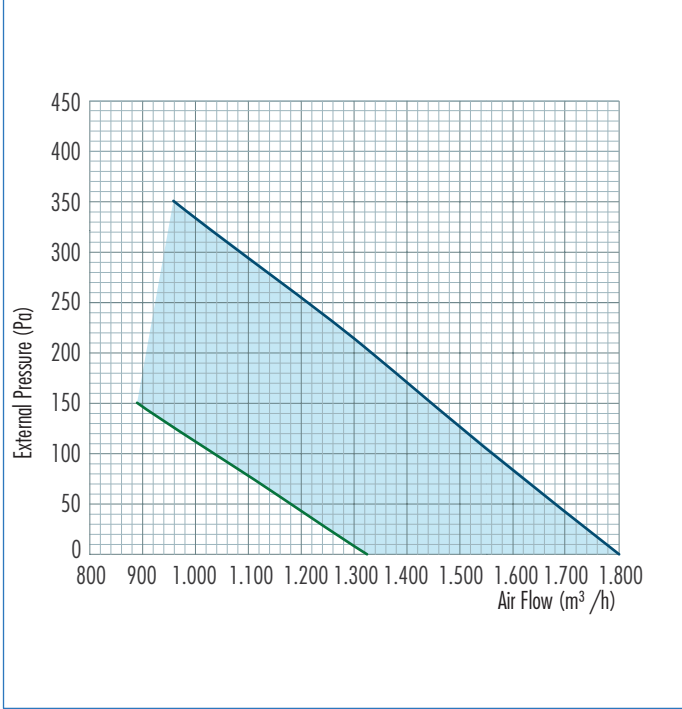

## ENERGY BOX TO - 2.400

PERFORMANCE CURVE

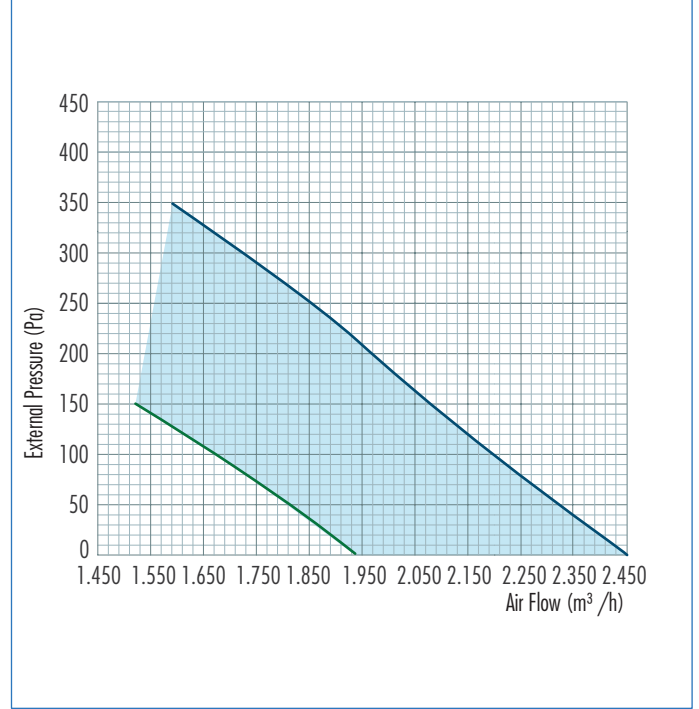

## ENERGY BOX - TO 1.800

SOUND CURVE

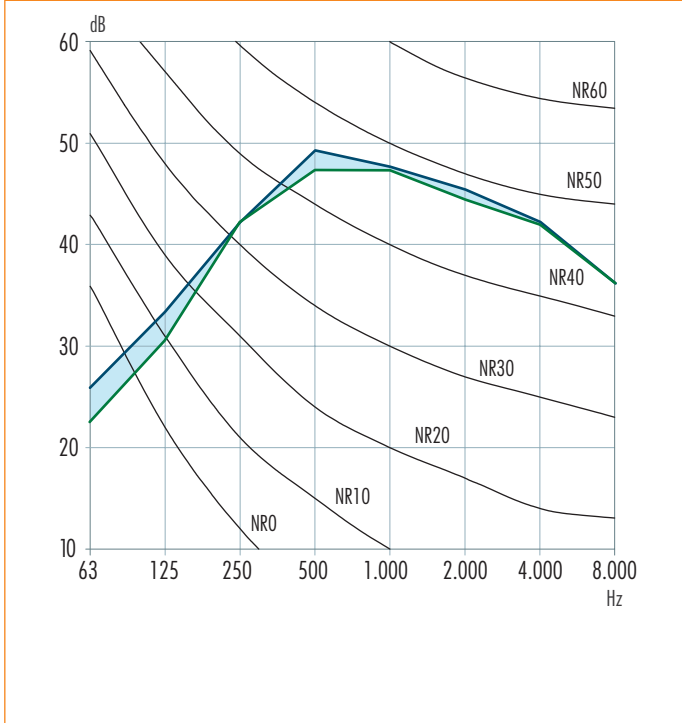

## ENERGY BOX TO - 2.400

SOUND CURVE

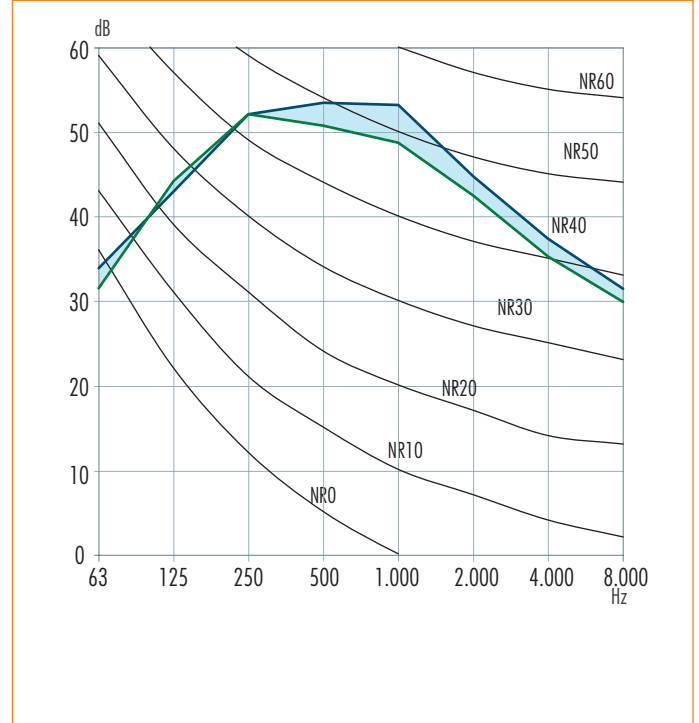



## Performance Data

### ENERGY BOX - TO 2.800

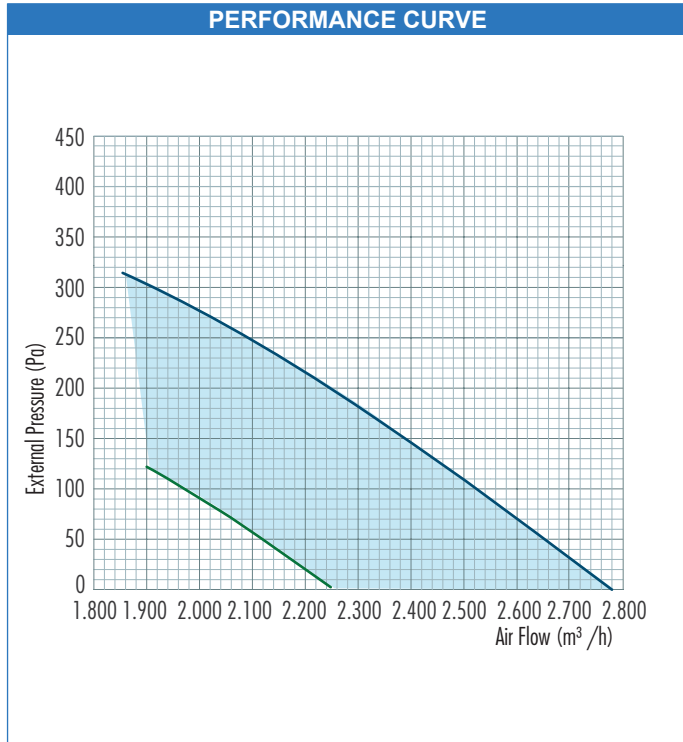

### ENERGY BOX - TO 3.500

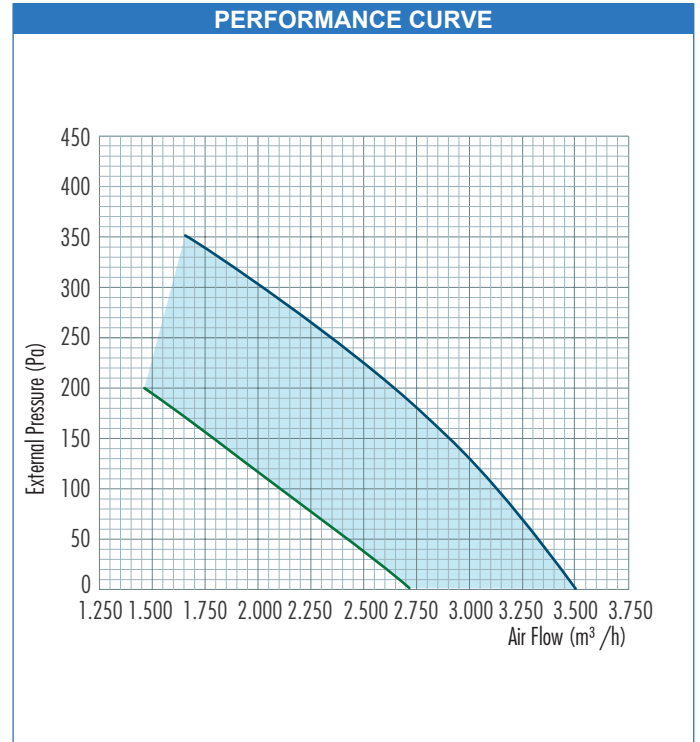

### ENERGY BOX - TO 2.800

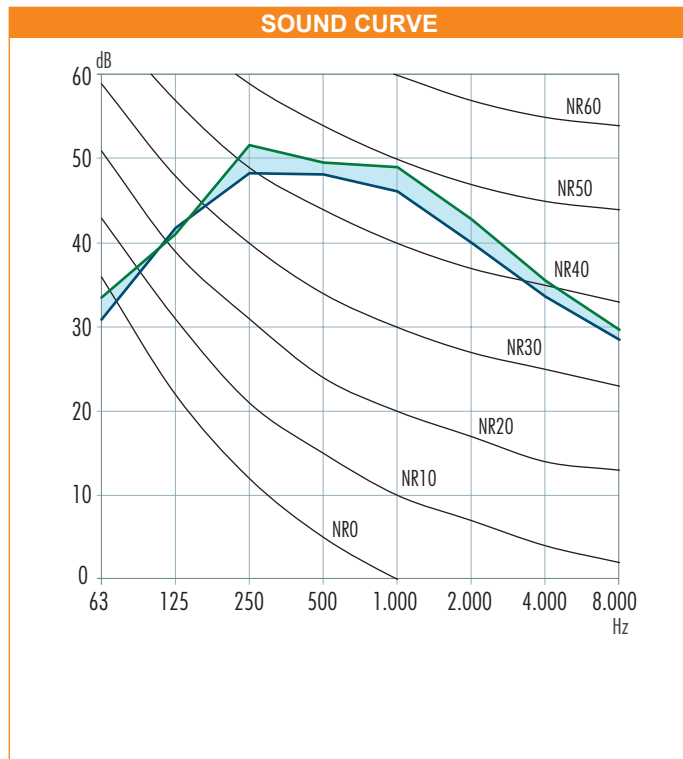

### ENERGY BOX - TO 3.500

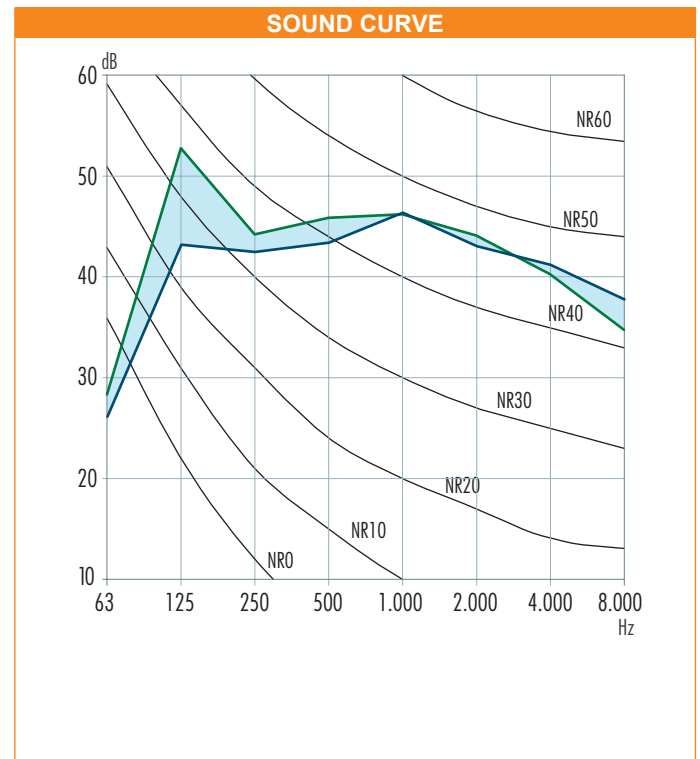



# Performance Data

## ENERGY BOX - TO 4.600

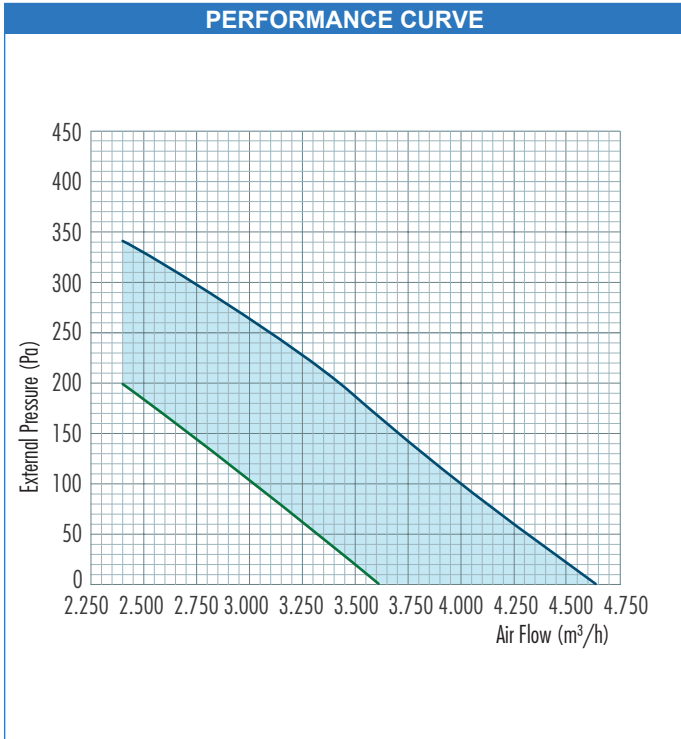

## ENERGY BOX - TO 5.700

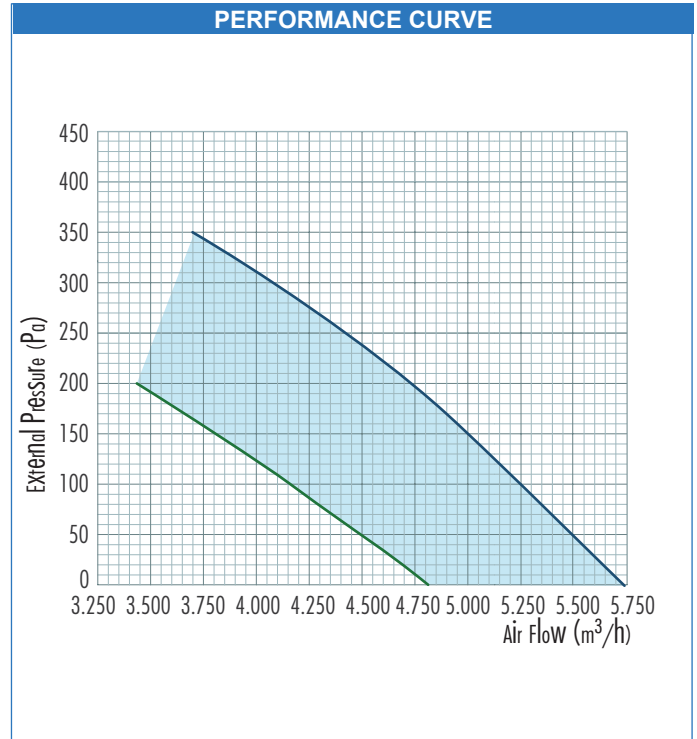

## ENERGY BOX - TO 4.600

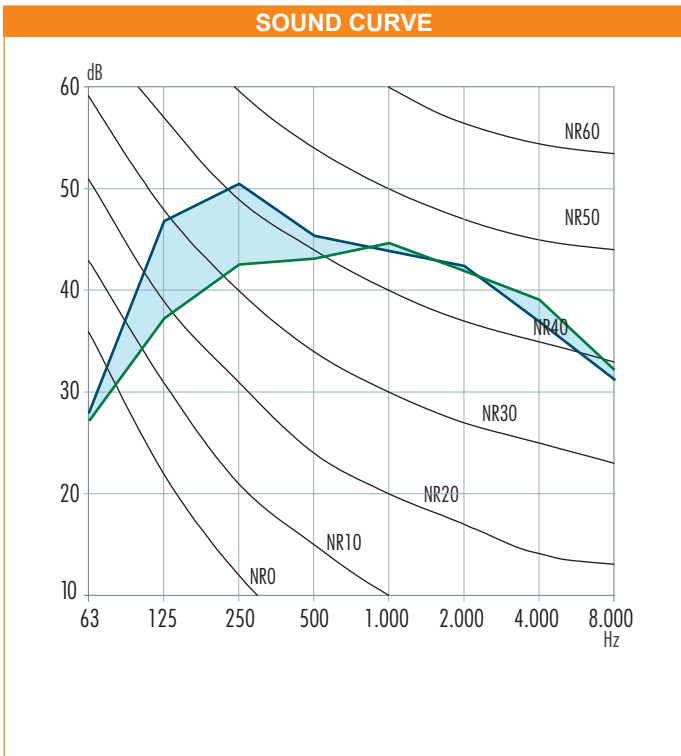

## ENERGY BOX - TO 5.700

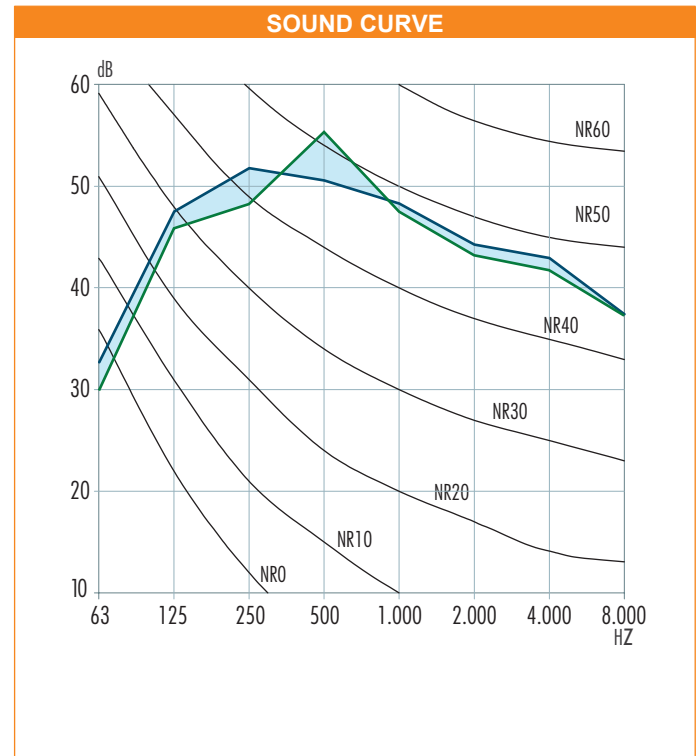



## Technical Specifications & Unit Dimensions

ENERGY BOX - TO		350	800	900	1.400	1.800	2.400	2.800	3.500	4.600	5.700
Air Flow *	m <sup>3</sup> /h	350	780	930	1.440	1.800	2.440	2.780	3.500	4.650	5.735
Supply Voltage	V/Hz/ph	230/ 50 /1~									
Max. Power Consumption	W	96	204	310	450	450	1.030	1.030	940	1.360	2.600
Max. Operation Current	A	0,44	0,9	1,36	2,0	2,0	4,5	4,5	4,1	6,0	11,6
Max. Sound Pressure **	dB	44	42	43	46	42	52	52	44	50	52
Unit Weight	kg	41	43	43	59	80	99	120	125	155	175
Filter Class		G Class Synthetic Filter According to EN 779									
Electric Heater***	kW	1	2	3	3	5	7	8	10	13	16
E.Heater Supply Voltage	V/Hz/ph	230 / 50 / 1~					400 / 50 / 3~				
Heater Coil (90/70 °C)	kW	-	2,9	4,3	6,4	8,3	11,4	14,2	17	22,8	26,9
Thermal Efficiency	%	Up to 55%	Up to 55%	Up to 55%	Up to 55%	Up to 55%	Up to 55%	Up to 55%	Up to 55%	Up to 55%	Up to 55%

\* External static pressure is 0 Pa.

\*\* Measured at 1,5m distance to the unit @ 250 Hz

\*\*\* Electrical heater and heater coil are optional. Electrical heaters shall be used before the fresh air inlet of the unit to preheat air where outdoor air is below -3°C and condensation can occur. Also in humid climates return air ducts must also be insulated against condensation.

### ENERGY BOX - TO Unit Dimensions

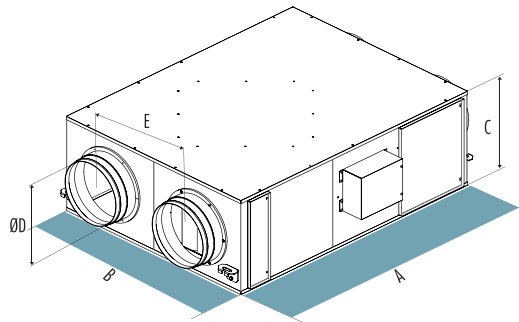

	350	780	930	1.400	1.800	2.400	2.800	3.500	4.600	5.700
A	872	930	930	1.072	1.192	1.335	1.570	1.570	1.805	2.150
B	550	675	675	826	980	1.120	1.160	1.160	1.240	1.350
C	280	335	335	375	430	430	540	540	640	680
E	273	336	336	412	488	558	577	577	622	675
ØD	Ø 160	Ø 200	Ø 250	Ø 250	Ø 300	Ø 355	Ø 355	Ø 355	Ø 450	Ø 500

\* All measurement values are mm.

### ENERGY BOX - TO Service Space & Installation

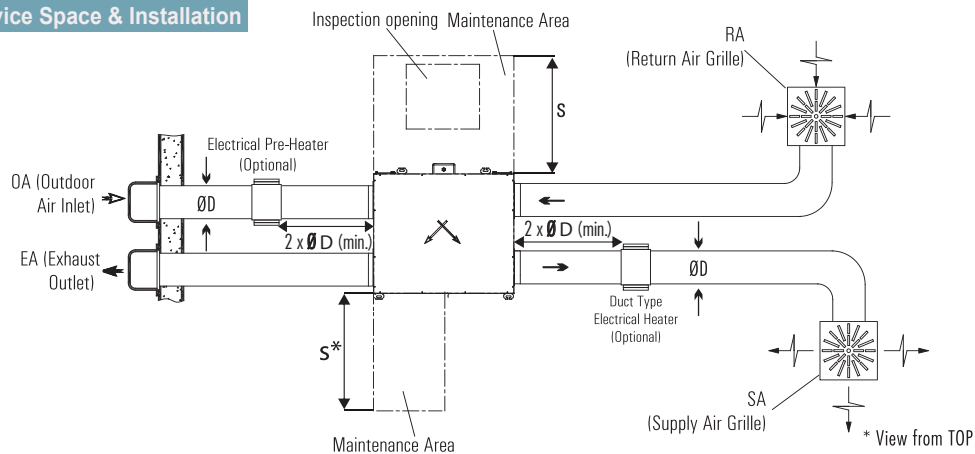

### ENERGY BOX - TO

	350	800	900	1.400	1.800	2.400	2.800	3.500	4.600	5.700
S	500	500	500	500	600	700	700	700	750	750

"S" and "S\*" values indicate the size of the service area.

\* All measurement values are mm.

\*For ENERGY BOX - TO 350 and ENERGY BOX - TO 4.600 models, do not need maintenance gap specified in "S\*" on technical drawing.

\*Drain pipe must be installed





## Control System



### ■ Stepless Control

- Stepless flow control
- Internal fuse
- On / Off function
- Flush mounted or Surface mounted
- Compact design



### ■ Stepless Control

- Stepless flow control
- Internal fuse
- On / Off function
- Surface mounted
- Compact design



ENERGY BOX - TO units can be delivered to the site with fan speed regulators. With fan speed regulators, both exhaust and supply air fans are regulated and unit also can be switched on/off. Mains electricity is connected to the fan speed regulator where ENERGY BOX - TO units shall be connected to the fan speed regulator there after. ENERGY BOX - TO 4.600 unit models are controlled on / off.

**ENERGY BOX - TO Speed Controller Wiring Diagram  
(Standard ENERGY BOX - TO Units)**

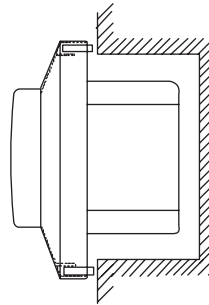
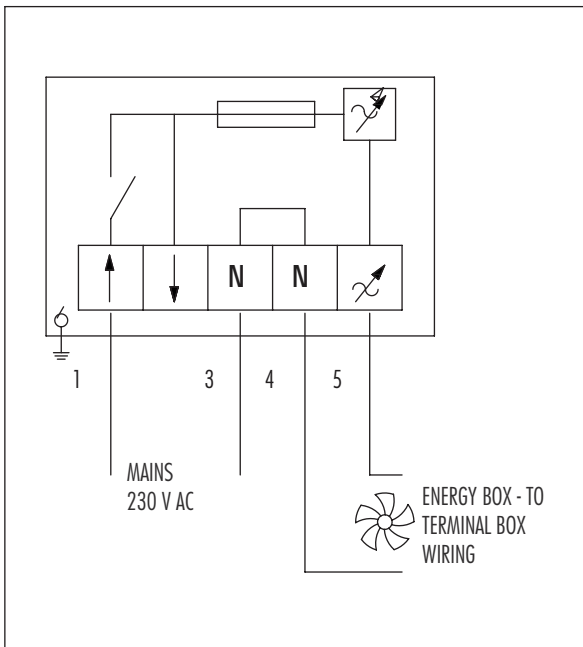

**Flush mounted**

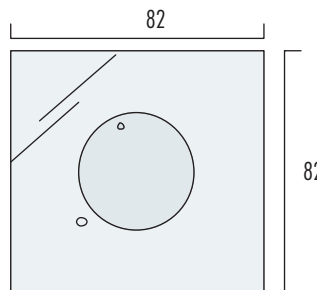
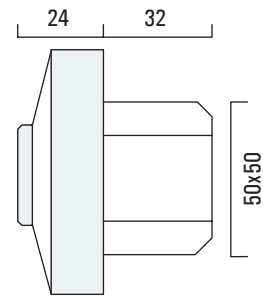

**Surface mounted**

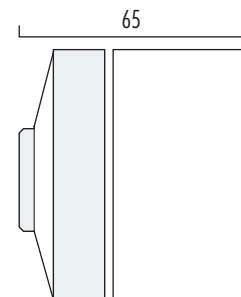







Dimensions in mm.



## Control System

Automation Options		Control Cards						
Standard	Optional	Standard Basic	Standard Pro	Alternative 1	Alternative 2	Alternative 3		
						Type 1	Type 2	Type 3
OA Temperature Sensor		☑	☑	☑	☑	☑	☑	☑
RA Temperature Sensor		☑	☑	☑	☑	☑	☑	☑
SA Fan Control		☑	☑	☑	☑	☑	☑	☑
RA Fan Control		☑	☑	☑	☑	☑	☑	☑
Filter Contamination Info (Time)		☑	☑	☑	☑	☑	☑	☑
Modbus RTU		☑	☑	☒	☑	☑	☑	☑
	On/Off Damper Control	☑	☑	☒	☑	☑	☑	☑
	Proportional Damper Control	☒	☒	☒	☑	☑	☑	☑
	Airflow Control			☒	☑		☑	
	Humidity Control	☒	☒	☑	☑	☒	☑	☒
	CO2 Control			☑	☑		☑	
	SA Temperature Sensor	☑	☑	☑	☑	☑	☑	☑
	On/Off Heating Coil	☑	☑	☒	☑	☑	☑	☑
	Proportional Heating Coil	☒	☒	☒	☑	☑	☑	☑
	On/Off Cooling Coil	☑	☑	☒	☑	☑	☑	☑
	Proportional Cooling Coil	☒	☒	☒	☑	☑	☑	☑
	Electrical Pre-Heater	☑	☑	☑	☑	☑	☑	☑
	Electrical After-Heater	☑	☑	☒	☑	☑	☑	☑
	BacNET MSTP	☒	☒	☒	☑	☑	☑	☑
	Web Browser (TCP/IP)	☒	☒	☒	☑	☒	☑	☒
	Weekly Timer	☒	☑	☒	☑	☑	☑	☑
	Filter Contamination Info (DPS)	☑	☑	☑	☑	☑	☑	☑

☒ Only one of them the defined functions is selectable for this control card.

Control Panel		Control Cards						
Panel Type	Panel Descriptions	Standard Basic	Standard Pro	Alternative 1	Alternative 2	Alternative 3		
						Type 1	Type 2	Type 3
	Standard-Basic Wall - mounted type Max : 30 m communication ability	☑	☒	☒	☒	☒	☒	☒
	Standard-Pro Wall - mounted type Max : 50 m communication ability	☒	☑	☒	☒	☒	☒	☒
	Alternative-1 Wall - mounted type Wireless Radio Frequency (RF) panel Max : 50 m communication ability	☒	☒	☑	☒	☒	☒	☒
	Alternative-2 Wall - mounted type hand panel, IP 30 protection class, Max : 100 m communication ability	☒	☒	☒	☑	☒	☒	☒
	Alternative-3.1 Wall - mounted type room panel, IP 30 protection class, Max : 700 m communication ability	☒	☒	☒	☒	☒	☒	☑
	Alternative-3.2 Hand Panel 1: Wall - mounted type, IP 65 protection class for only front side of panel, Max:50 m communication ability Hand Panel 2: Magnet type, IP 65 protection class for whole panel, Max : 50 m communication ability	☒	☒	☒	☒	☑	☑	☑
	Alternative-3.3 Magnet type, IP 31 protection class, Max : 700 m communication ability	☒	☒	☒	☒	☑	☑	☑



## Control System

### ■ Selection of Electrical Cable Cross-Section

Unit Model ENERGY BOX - TO	Unit Voltage (V)	Unit Power Input (kW)	Current (A)	Fuse (A)	Cable Cross - Section (mm <sup>2</sup> ) for 50 m and PF = 0,8
350	230	0,10	1,00	1	1,5
800	230	0,20	1,00	2	1,5
900	230	0,30	2,00	3	1,5
1.400	230	0,45	3,00	3	1,5
1.800	230	0,45	3,00	3	1,5
2.400	230	1,03	6,00	10	1,5
2.800	230	1,03	6,00	10	1,5
3.500	230	0,94	6,00	10	1,5
4.600	230	1,36	8,00	10	1,5
5.700	230	2,60	14,2	16	1,5

### ■ Cable Cross-Section Formulas

$$1 \quad I_{\text{current}} = \frac{P}{U \cdot \cos Q}$$

$$I_{\text{cable}} > I_{\text{current}}$$

2

$$\%e = \frac{100 \cdot P \cdot L}{k \cdot S \cdot U^2}, \quad S = \frac{100 \cdot P \cdot L}{k \cdot \%e \cdot U^2}$$

$$\%e = \%3$$

3

$$I_{\text{cable}} > I_{\text{fuse}} \geq I_{\text{current}}$$

$$\text{Cable Cross-Section } S = \text{Max} (S1, S2, S3, 1.5\text{mm}^2)$$

P : Power

I : Current

U : Voltage

S : Conductor cross section

k : Conductor coefficient

L : Conductor length

%e : The voltage drop

### ■ Example of Cable Cross-Section Calculation

$$P : 2,6 \text{ kW} \quad L : 50 \text{ m}$$

$$U : 230 \text{ V} \quad \%e : \%3$$

$$PF : \cos Q : 0,8 \quad k : 56 \text{ m} / \Omega$$

1

$$I_{\text{current}} = \frac{2600 \text{ W}}{230 \cdot 0,8} = 14,2 \text{ A}$$

The cable will be used, is selected from the cable cross-section table so that the equivalent ampere value in the table should be higher than calculated "I<sub>current</sub>" value.

$$S1 = 1,5 \text{ mm}^2$$

2

$$\%e = \%3$$

$$S = \frac{100 \cdot 2600 \cdot 50}{56 \cdot 3 \cdot 230^2} = 1,46 \text{ mm}^2$$

$$S2 \geq 1,46 \text{ mm}^2 \geq 1,5 \text{ mm}^2$$

$$S2 = 1,5 \text{ mm}^2$$

3

$$I_{\text{cable}} > I_{\text{fuse}} \geq I_{\text{current}}$$

$$I_{\text{cable}} > 16 \text{ A} \geq 14,2 \text{ A}$$

"I<sub>fuse</sub>" which will be higher than "I<sub>current</sub>", is selected.

The cable will be used, is selected from the cable cross-section table so that the equivalent ampere value in the table should be higher than selected "I<sub>fuse</sub>" value.

$$I_{\text{cable}} = 24 \text{ A}$$

$$S3 = 1,5 \text{ mm}^2$$

$$\text{Cable cross-section } S = \text{Max} (S1, S2, S3, 1,5 \text{ mm}^2)$$

$$S = \text{Max} (1,5, 1,5, 1,5, 1,5)$$

$$S = 1,5 \text{ mm}^2$$



## Accessories

### ■ Duct Type Electric Heater



Electric heaters are optionally supplied in cold climates for supply air and in extreme climates for both supply and outdoor air sides against freezing. Electric heaters are manufactured according to circular or rectangular duct systems. Standard types are produced of stainless steel heating elements and galvanized metal casing. Stainless steel casing is also available.

Electric heaters are equipped with two excessive temperature protection. When inside of the electric heater's temperature is 70°C, "automatic excessive temperature protection" enables and electric heater disables automatically. When 70°C automatic temperature protection doesn't enable or the inside of the electric heater's temperature is 110°C, the second protection enables and electric heater disables until the manual reset will be done.

The electrical heaters, designed as maximum 2 steps, step automatically according to temperature that is set on room control panel with control panel.

ENERGY BOX - TO electric heaters are connected in Delta connection in standard models.

Heating Capacity Calculation  $Q = 0,33 \times V \times (T_2 - T_1)$

Q : Heating Capacity (W) T<sub>1</sub> : Air temperature before the heater ( °C)  
V : Air Flow through electric heater (m<sup>3</sup>/h) T<sub>2</sub> : Air temperature after the heater ( °C)

### ■ Duct Type Coils



Duct type heating/cooling coils are assembled in cabin as suitable to mount inside duct and have standard capacity. Coils consist of copper tubes and aluminum fins. Inlets and outlets of cabin are suitable for circular duct connections as in heat recovery ventilation units. Additionally, cooling coils have drain pan and extra insulation to prevent condensation of cabin. Both heating and cooling coils can be controlled separately as on/off via unit automation system.

### ■ Ventilation on Demand

Air Quality Sensor is mounted to the return air duct and is connected to control system of unit. The set point for the desired indoor air quality is set during the installation. According to the demand indoors, ENERGY BOX - TO units are modulated automatically by the sensor. Annual energy consumption of the unit is reduced as a result of the modulation, ending in reduction in energy costs.

Fresh air demand in a space is calculated according to human occupancy and/or physical properties of the conditioned space. The calculation is based on the maximum indoor occupancy. In practice maximum occupancy is observed for only a small period of time annually where lower air flow rates will be sufficient for most of the year. By reducing the air flow rate according to the fresh air demand; it is possible to reduce units electrical consumption and reduce also energy consumption used to condition the space. It should be noted that by increasing fresh air rate, indoors heating/cooling demand will also be increased.

With the help of control kit of unit, it is possible to regulate fresh air rate according to the demand indoors. Indoor air quality sensor or CO<sub>2</sub> sensor is mounted to the return duct or the conditioned space and the demanded condition is set. A 0-10 V signal will be created and ENERGY BOX TO unit's air flow will be regulated according to the signal.

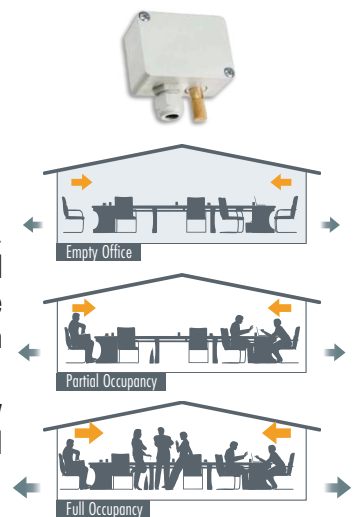

### ■ Sound Attenuator For Circular Ducts

Sound attenuators are designed for standard duct dimensions. Various lengths are available according to attenuation demand. Sound attenuation capacities are given in the table. For better performance sound attenuators can be used in series. For the best result the sound attenuators shall be installed just after the unit.



Sound Attenuation Capacity [dB]

Sound Attenuator Dimensions [mm]

CSA	63	125	250	500	1k	2k	4k	8k	length (L)	Ø d	Ø do
200 - 300	1	2	3	6	10	14	12	14	300	200	300
200 - 600	2	3	6	7	13	17	18	20	600	200	300
200 - 900	3	4	7	10	16	18	21	22	900	200	300
250 - 300	1	2	6	6	13	16	14	15	300	250	350
250 - 600	2	3	7	7	18	21	20	22	600	250	350
250 - 900	3	4	9	8	21	24	21	23	900	250	350
300 - 300	1	2	4	4	10	12	12	15	300	300	400
300 - 600	1	3	6	7	13	15	17	19	600	300	400
300 - 900	2	4	7	8	15	17	18	21	900	300	400
355 - 600	1	3	8	8	9	6	5	7	600	355	450
355 - 900	4	4	13	13	11	7	6	8	900	355	450

Notation

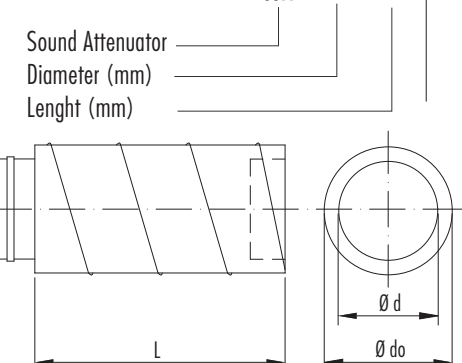



Management System  
ISO 14001:2015  
Valid until:  
2024-09-24



www.air.com  
ID: 9108650718

ISO 9001:2015

ISO 14001:2015

### AIR HANDLING UNITS





### HEAT EXCHANGERS





### FAN COIL UNITS



### FANS & FAN SECTIONS





### FIRE DAMPERS



### AIR OUTLETS



### STEAM HUMIDIFIERS - DEHUMIDIFIERS



### CENTRAL VACUUM SYSTEMS



TUBO  
THINK CLEAN

### STAINLESS STEEL CHIMNEYS



### AIR FILTERS



### AIR CURTAINS



### EVAPORATIVE COOLING





#### Main Office ATHENS

📍 Michail Karaoli Str. 19,  
14343, Nea Chalkidona, Athens  
211 - 705.55.00

✉ sales@airtechnic.gr

#### Factory - THIVA

📍 4<sup>th</sup> km Thiva - Chalkida Hwy,  
32200, Thiva  
22620 - 89.006

✉ factory@airtechnic.gr

#### Factory - THESSALONIKI

📍 End of Meandrou Str.,  
57013, Oraiakastro, Thessaloniki  
2311 - 82.40.00

✉ thessaloniki@airtechnic.gr