



# HCT/MAR HFT/MAR

**HCT/MAR: Robust cased axial fans for fitting between ducts, for marine and naval applications**

**HFT/MAR: Cased axial fans for start of duct, very tough for marine and naval applications**



HCT/MAR



HFT/MAR

Circular axial fans with two flanges (HFT) or long cased axial fans for fitting between ducts (HCT), for operating in marine environments, fitted with motors suitable for marine service

**Fan:**

- HFT/MAR: Support ring with two flanges made from highly robust hot galvanised sheet steel
- HCT/MAR: Tubular hot-galvanised casing in sheet steel of great strength, to fit between ducts
- Impeller made from cast aluminium
- Incorporates with inspection hatch (HCT)
- Airflow direction from motor to impeller

**Motor:**

- Motors for class F marine service, with ball bearings, IP55 protection, complying with classification for non-essential naval service.
- IE3 efficiency for 7.5kW and larger motors. Except single-phase, 2 speed and 8 pole motors

- Three phase, 50Hz, 230/400V motors up to and including 4kW. 400/690V over 4kW
- Max. air temperature to transport: -20°C+ 60°C

**Finish:**

- Hot galvanised anticorrosive

**On request:**

- Made from stainless steel
- Special windings for different electrical supplies and frequencies
- ATEX construction for different categories
- Built-in motors with PTC
- Marine motors for naval applications with certification for essential service by various classifying societies (BV, DNV, LR)
- IE2 and IE3 efficiency motors assembled on any unit

The marine motors used may be certified by most international marine classification bodies:

ABS: American Bureau of Shipping

BV: Bureau Veritas

CCS: China Classification Societies

CR: China Corporation Register of Shipping

DNV: Det Norske Veritas

GL: Germanischer Lloyd

KR: Korean Register of Shipping

LR: Lloyd's Register of Shipping

NK: Nippon Kaiji Kyokai

RINA: Registro Italiano Navale

RS: Russian Maritime Register of Shipping

**Order code**

**HCT/MAR — 56 — 4T — 1,5**

HCT/MAR: Robust cased axial fans for marine and naval applications  
HFT/MAR: Cased axial fans for marine and naval applications

Impeller diameter (cm)

Number of motor pole  
2=2900 r/min. 50 Hz  
4=1400 r/min. 50 Hz  
6=900 r/min. 50 Hz

T=Three-phase Motor power (HP)

**Technical characteristics**

Model	Speed (r/min)	Maximum current admissible (A)			Installed power (kW)	Maximum airflow (m³/h)	Sound pressure level dB(A)	Approx. weight with motor (Kg)	
		230V	400V	690V				HCT/MAR	HFT/MAR
HCT/MAR 35-2T	2710	1.92	1.11		0.37	5750	77	13	
HCT/MAR 35-4T	1320	0.65	0.38		0.09	3100	59	12	
HCT/MAR 40-2T-1.5	2860	4.20	2.40		1.10	8800	84	27	
HCT/MAR 40-4T-0.33	1350	1.66	0.96		0.25	5150	64	21	
HCT/MAR 45-2T-2	2770	5.44	3.13		1.50	10650	86	30	
HCT/MAR 45-2T-3	2885	7.77	4.47		2.20	12750	88	33	
HCT/MAR 45-4T-0.5	1370	2.02	1.17		0.37	7100	68	25	
HCT/MAR 50-4T-0.75	1380	2.92	1.69		0.55	10400	70	27	
HCT/MAR HFT/MAR 56-4T-0.75	1380	2.92	1.69		0.55	11050	72	32	22
HCT/MAR HFT/MAR 56-4T-1	1410	3.10	1.79		0.75	12950	73	34	23

**Technical characteristics**

Model	Speed (r/min)	Maximum current admissible (A)			Installed power (kW)	Maximum airflow (m³/h)	Sound pres- sure level dB(A)	Approx. weight with motor (Kg)	
		230V	400V	690V				HCT/MAR	HFT/MAR
HCT/MAR HFT/MAR 56-4T-1.5	1400	4.03	2.32		1.10	14000	74	36	27
HCT/MAR HFT/MAR 56-4T-2	1430	5.96	3.44		1.50	15300	75	39	29
HCT/MAR HFT/MAR 56-6T-0.33	900	1.51	0.87		0.25	8500	61	31	19
HCT/MAR HFT/MAR 56-6T-0.5	900	2.24	1.30		0.37	9300	61	34	21
HCT/MAR HFT/MAR 56-6T-0.75	900	2.99	1.73		0.55	10000	62	34	23
HCT/MAR HFT/MAR 63-4T-1	1410	3.10	1.79		0.75	14150	73	43	29
HCT/MAR HFT/MAR 63-4T-1.5	1400	4.03	2.32		1.10	17000	74	45	32
HCT/MAR HFT/MAR 63-4T-2	1430	5.96	3.44		1.50	18900	75	48	35
HCT/MAR HFT/MAR 63-4T-3	1445	8.36	4.83		2.20	22100	76	53	43
HCT/MAR HFT/MAR 63-4T-4	1445	10.96	6.33		3.00	25400	77	56	79
HCT/MAR HFT/MAR 63-6T-0.5	900	2.24	1.30		0.37	12150	64	43	27
HCT/MAR HFT/MAR 63-6T-0.75	900	2.99	1.73		0.55	12750	65	43	29
HCT/MAR HFT/MAR 63-6T-1	945	3.90	2.20		0.75	13800	66	45	35
HCT/MAR HFT/MAR 71-4T-1.5	1400	4.03	2.32		1.10	19750	78	51	35
HCT/MAR HFT/MAR 71-4T-2	1430	5.96	3.44		1.50	21100	79	54	38
HCT/MAR HFT/MAR 71-4T-3	1445	8.36	4.83		2.20	23950	81	60	47
HCT/MAR HFT/MAR 71-4T-4	1445	10.96	6.33		3.00	29400	82	63	49
HCT/MAR HFT/MAR 71-6T-0.75	900	2.99	1.73		0.55	15150	67	49	31
HCT/MAR HFT/MAR 71-6T-1	945	3.90	2.20		0.75	17250	68	51	38
HCT/MAR HFT/MAR 71-6T-1.5	945	4.88	2.82		1.10	20950	69	54	40
HCT/MAR HFT/MAR 80-4T-3	1445	8.36	4.83		2.20	28000	82	69	55
HCT/MAR HFT/MAR 80-4T-4	1445	10.96	6.33		3.00	32700	83	72	57
HCT/MAR HFT/MAR 80-4T-5.5	1440	14.10	8.12		4.00	37200	84	74	62
HCT/MAR HFT/MAR 80-6T-1	945	3.90	2.20		0.75	20600	71	60	46
HCT/MAR HFT/MAR 80-6T-1.5	945	4.88	2.82		1.10	24250	72	63	48
HCT/MAR HFT/MAR 80-6T-2	955	6.42	3.71		1.50	28000	73	71	54
HCT/MAR HFT/MAR 80-6T-3	955	9.30	5.30		2.20	32500	74	74	59
HCT/MAR HFT/MAR 90-4T-4	1445	10.96	6.33		3.00	37750	87	87	64
HCT/MAR HFT/MAR 90-4T-5.5	1440	14.10	8.12		4.00	41850	89	90	69
HCT/MAR HFT/MAR 90-4T-7.5	1440		11.60	6.72	5.50	47000	91	103	85
HCT/MAR HFT/MAR 90-4T-10 IE3	1465		13.90	8.06	7.50	53000	92	127	112
HCT/MAR HFT/MAR 90-6T-2	955	6.42	3.71		1.50	30000	77	86	61
HCT/MAR HFT/MAR 90-6T-3	955	9.30	5.30		2.20	35000	78	90	66
HCT/MAR HFT/MAR 90-6T-4	960	12.70	7.30		3.00	40000	79	102	90
HCT/MAR HFT/MAR 100-4T-7.5	1440		11.60	6.72	5.50	52500	92	115	93
HCT/MAR HFT/MAR 100-4T-10 IE3	1465		13.90	8.06	7.50	58500	93	138	120
HCT/MAR HFT/MAR 100-4T-15 IE3	1470		20.90	12.10	11.00	68000	94	184	152
HCT/MAR HFT/MAR 100-4T-20 IE3	1465		27.90	16.20	15.00	71850	95	195	163
HCT/MAR HFT/MAR 100-6T-3	955	9.30	5.30		2.20	40500	82	101	74
HCT/MAR HFT/MAR 100-6T-4	960	12.70	7.30		3.00	46950	83	113	98
HCT/MAR HFT/MAR 100-6T-5.5	960	16.50	9.46		4.00	52000	84	120	106

**Acoustic features**

The specified values are determined according to free field measurements of pressure and sound levels in dB(A) at an equivalent distance of twice the fan's span plus the impeller's diameter, with a minimum of 1.5 m.

Sound power Lw(A) spectrum in dB(A) via frequency band in Hz.

Model	63	125	250	500	1000	2000	4000	8000	Model	63	125	250	500	1000	2000	4000	8000
35-2T	48	63	82	81	82	81	76	67	71-4T-4	59	79	87	92	94	91	84	73
35-4T	30	45	64	63	64	63	58	49	71-6T-0.75	44	64	72	77	79	76	69	58
40-2T-1.5	55	70	89	88	89	88	83	74	71-6T-1	45	65	73	78	80	77	70	59
40-4T-0.33	35	50	69	68	69	68	63	54	71-6T-1.5	46	66	74	79	81	78	71	60
45-2T-2	51	68	80	88	93	93	89	82	80-4T-3	59	79	87	92	94	91	84	73
45-2T-3	53	70	82	90	95	95	91	84	80-4T-4	60	80	88	93	95	92	85	74
45-4T-0.5	33	50	62	70	75	75	71	64	80-4T-5.5	61	81	89	94	96	93	86	75
50-4T-0.75	37	54	67	74	79	80	75	68	80-6T-1	48	68	76	81	83	80	73	62
56-4T-0.75	47	67	75	80	82	79	72	61	80-6T-1.5	49	69	77	82	84	81	74	63
56-4T-1	48	68	76	81	83	80	73	62	80-6T-2	50	70	78	83	85	82	75	64
56-4T-1.5	49	69	77	82	84	81	74	63	80-6T-3	51	71	79	84	86	83	76	65
56-4T-2	50	70	78	83	85	82	75	64	90-4T-4	65	86	93	98	101	97	90	79
56-6T-0.33	36	56	64	69	71	68	61	50	90-4T-5.5	67	88	95	100	103	99	92	81
56-6T-0.5	36	56	64	69	71	68	61	50	90-4T-7.5	69	90	97	102	105	101	94	83
56-6T-0.75	37	57	65	70	72	69	62	51	90-4T-10	70	91	98	103	106	102	95	84
63-4T-1	50	70	78	83	85	82	75	64	90-6T-2	55	76	83	88	91	87	80	69
63-4T-1.5	51	71	79	84	86	83	76	65	90-6T-3	56	77	84	89	92	88	81	70
63-4T-2	52	72	80	85	87	84	77	66	90-6T-4	57	78	85	90	93	89	82	71
63-4T-3	53	73	81	86	88	85	78	67	100-4T-7.5	72	92	100	105	107	104	97	86
63-4T-4	54	74	82	87	89	86	79	68	100-4T-10	73	93	101	106	108	105	98	87
63-6T-0.5	41	61	69	74	76	73	66	55	100-4T-15	74	94	102	107	109	106	99	88
63-6T-0.75	42	62	70	75	77	74	67	56	100-4T-20	75	95	103	108	110	107	100	89
63-6T-1	43	63	71	76	78	75	68	57	100-6T-3	62	82	90	95	97	94	87	76
71-4T-1.5	55	75	83	88	90	87	80	69	100-6T-4	63	83	91	96	98	95	88	77
71-4T-2	56	76	84	89	91	88	81	70	100-6T-5.5	64	84	92	97	99	96	89	78
71-4T-3	58	78	86	91	93	90	83	72									

Dimensions in mm

HCT/MAR

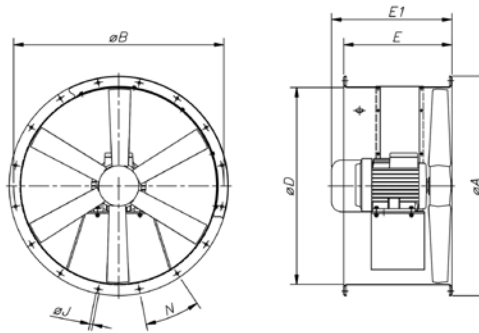

Model	ØA	ØB	ØD	E	E1	ØJ	N
HCT/MAR-35-2T	425	395	355	280	-	10	8x45°
HCT/MAR-35-4T	425	395	355	280	-	10	8x45°
HCT/MAR-40-2T-1.5	490	450	410	400	-	12	8x45°
HCT/MAR-40-4T-0.33	490	450	410	400	-	12	8x45°
HCT/MAR-45-2T-2	540	500	460	400	-	12	8x45°
HCT/MAR-45-2T-3	540	500	460	400	-	12	8x45°
HCT/MAR-45-4T-0.5	540	500	460	400	-	12	8x45°
HCT/MAR-50-4T-0.75	600	560	514	400	-	12	12x30°
HCT/MAR-56-4T-0.75	660	620	560	400	-	12	12x30°
HCT/MAR-56-4T-1	660	620	560	400	-	12	12x30°
HCT/MAR-56-4T-1.5	660	620	560	400	-	12	12x30°
HCT/MAR-56-4T-2	660	620	560	400	-	12	12x30°
HCT/MAR-56-6T-0.33	660	620	560	400	-	12	12x30°
HCT/MAR-56-6T-0.5	660	620	560	400	-	12	12x30°
HCT/MAR-56-6T-0.75	660	620	560	400	-	12	12x30°
HCT/MAR-63-4T-1	730	690	640	400	-	12	12x30°
HCT/MAR-63-4T-1.5	730	690	640	400	-	12	12x30°
HCT/MAR-63-4T-2	730	690	640	400	-	12	12x30°
HCT/MAR-63-4T-3	730	690	640	500	-	12	12x30°
HCT/MAR-63-4T-4	730	690	640	500	-	12	12x30°
HCT/MAR-63-6T-0.5	730	690	640	400	-	12	12x30°
HCT/MAR-63-6T-0.75	730	690	640	400	-	12	12x30°
HCT/MAR-63-6T-1	730	690	640	400	-	12	12x30°
HCT/MAR-71-4T-1.5	810	770	710	430	-	12	16x22°30'
HCT/MAR-71-4T-2	810	770	710	430	-	12	16x22°30'
HCT/MAR-71-4T-3	810	770	710	500	-	12	16x22°30'

Model	ØA	ØB	ØD	E	E1	ØJ	N
HCT/MAR-71-4T-4	810	770	710	500	-	12	16x22°30'
HCT/MAR-71-6T-0.75	810	770	710	430	-	12	16x22°30'
HCT/MAR-71-6T-1	810	770	710	500	-	12	16x22°30'
HCT/MAR-71-6T-1.5	810	770	710	500	-	12	16x22°30'
HCT/MAR-80-4T-3	900	860	800	500	-	12	16x22°30'
HCT/MAR-80-4T-4	900	860	800	500	-	12	16x22°30'
HCT/MAR-80-4T-5.5	900	860	800	500	-	12	16x22°30'
HCT/MAR-80-6T-1	900	860	800	500	-	12	16x22°30'
HCT/MAR-80-6T-1.5	900	860	800	500	-	12	16x22°30'
HCT/MAR-80-6T-2	900	860	800	500	-	12	16x22°30'
HCT/MAR-80-6T-3	900	860	800	500	-	12	16x22°30'
HCT/MAR-90-4T-4	1015	970	900	600	-	15	16x22°30'
HCT/MAR-90-4T-5.5	1015	970	900	600	-	15	16x22°30'
HCT/MAR-90-4T-7.5	1015	970	900	600	-	15	16x22°30'
HCT/MAR-90-4T-10	1015	970	900	600	-	15	16x22°30'
HCT/MAR-90-6T-2	1015	970	900	600	-	15	16x22°30'
HCT/MAR-90-6T-3	1015	970	900	600	-	15	16x22°30'
HCT/MAR-90-6T-4	1015	970	900	600	-	15	16x22°30'
HCT/MAR-100-4T-7.5	1115	1070	1000	600	-	15	16x22°30'
HCT/MAR-100-4T-10	1115	1070	1000	600	-	15	16x22°30'
HCT/MAR-100-4T-15	1115	1070	1000	700	-	15	16x22°30'
HCT/MAR-100-4T-20	1115	1070	1000	700	-	15	16x22°30'
HCT/MAR-100-6T-3	1115	1070	1000	600	-	15	16x22°30'
HCT/MAR-100-6T-4	1115	1070	1000	600	-	15	16x22°30'
HCT/MAR-100-6T-5.5	1115	1070	1000	600	-	15	16x22°30'

HFT/MAR

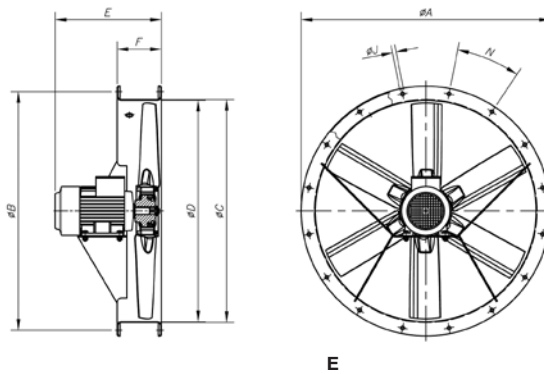

Model	øA	øB	øC	øD	E													F	øJ	N
					0.33	0.5	0.75	1	1.5	2	3	4	5.5	7.5	10	15	20			
HFT/MAR-56-4	660	620	564	560	-	-	344	344	376	376	-	-	-	-	-	-	-	150	12	12x30°
HFT/MAR-56-6	660	620	564	560	310	344	344	-	-	-	-	-	-	-	-	-	-	150	12	12x30°
HFT/MAR-63-4	730	690	645	640	-	-	-	325	398	398	430	430	-	-	-	-	-	150	12	12x30°
HFT/MAR-63-6	730	690	645	640	-	325	325	398	-	-	-	-	-	-	-	-	-	150	12	12x30°
HFT/MAR-71-4	810	770	715	710	-	-	-	400	400	440	440	-	-	-	-	-	-	150	12	16x22°30'
HFT/MAR-71-6	810	770	715	710	-	-	325	400	400	-	-	-	-	-	-	-	-	150	12	16x22°30'
HFT/MAR-80-4	900	860	805	800	-	-	-	-	-	425	425	445	-	-	-	-	-	180	12	16x22°30'
HFT/MAR-80-6	900	860	805	800	-	-	-	390	390	425	445	-	-	-	-	-	-	180	12	16x22°30'
HFT/MAR-90-4	1015	970	906	900	-	-	-	-	-	-	430	440	470	470	-	-	-	180	15	16x22°30'
HFT/MAR-90-6	1015	970	906	900	-	-	-	-	430	440	470	-	-	-	-	-	-	180	15	16x22°30'
HFT/MAR-100-4	1115	1070	1006	1000	-	-	-	-	-	-	-	-	485	485	590	590	200	15	16x22°30'	
HFT/MAR-100-6	1115	1070	1006	1000	-	-	-	-	-	-	440	485	485	-	-	-	200	15	16x22°30'	

Characteristic Curves

See page 143