

**SOUND-INSULATED FANS**

**VENTS Stream series**



Inline mixed-flow fans in sound- and heat-insulated casing with the air flow up to **540 m<sup>3</sup>/h**

**Application**

VENTS Stream series of duct fans in a special sound-insulated casing, which ensures silent operation of the fan with high aerodynamic characteristics. Compatible with air ducts with a diameter of 100, 125, 150, 160 mm.

VENTS Stream fans combine the wide capabilities and high performance characteristics of axial and centrifugal fans, providing a powerful air flow and high pressure.

They are used in supply and exhaust ventilation systems of various commercial and industrial premises with increased noise level requirements (libraries, conference rooms, educational institutions, kindergartens, etc.).

**Design**

The casing and impeller are made of high quality and durable plastic. The internal perforation of the casing allows sound waves to pass through, directing them at a certain angle to a layer of sound-absorbing material. The casing is internally heat- and sound-insulated with a 50 mm mineral wool layer.

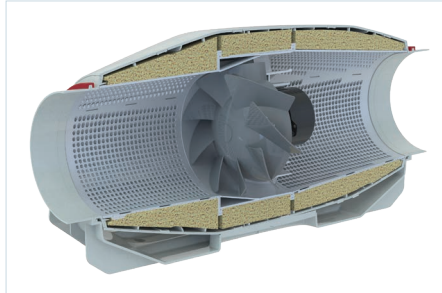

The special perforation of the casing and the sound-absorbing material ensure sound attenuation in a wide frequency range. Due to the conical shape of the impeller and specially shaped blades, the circular speed of the air flow is increased, providing higher pressure and performance compared to standard axial fans.

The diffuser, the specially profiled impeller and the directing vanes at the outlet of the fan casing distribute the air flow in such a way as to attain the best combination of high performance and high pressure at low noise level.

The fan casing is equipped with an external sealed terminal box for connection to power mains.

**Electric motor**

Single-phase energy efficient three-speed motors with low energy demand are used. The fan motors are equipped with thermal fuses for overload protection. The ball bearings provide a long service life (about 40 000 hours of continuous operation).

The motor protection class is IPX4.

**Speed control**

The three-speed motor can be controlled using a built-in switch (option "V") or an external switch for multi-speed fans (purchased separately).

A built-in speed controller (option "P"), an external TRIAC or autotransformer speed controller (available upon separate order) enable smooth motor speed control when connected to the maximum speed terminal.

The models with the "T" option are equipped with a turn-off delay timer, adjustable from 2 to 30 minutes.

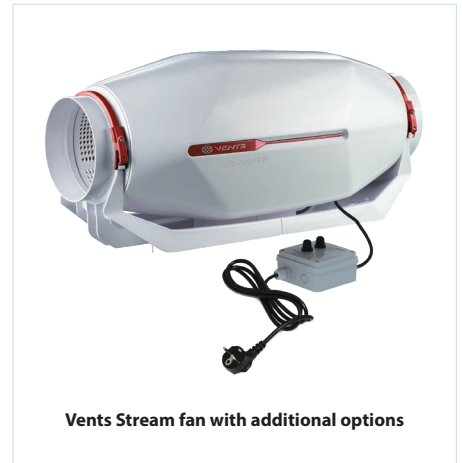

**Vents Stream fan with additional options**

**Mounting**

The fans can be installed at the beginning, in the middle or at the end of the duct system.

Mounting at any angle relative to the fan axis is allowed.

In one system, it is possible to install several fans in parallel to increase the air flow or in series to increase the operating pressure.

The fan casing is equipped with mounting brackets for floor, wall or ceiling mounting.

**Designation key**

Series	Air duct diameter	Options
<b>VENTS Stream</b>	100; 125; 150; 160	<p><b>T:</b> adjustable turn-off delay timer, from 2 to 30 min.</p> <p><b>Un:</b> speed controller with an electronic thermostat and a temperature sensor, fixed on a 4 m cable. Temperature-based operation logic.</p> <p><b>R:</b> power cord with a mains plug.</p> <p><b>V:</b> three-position speed switch.</p> <p><b>P:</b> integrated smooth speed controller.</p>

**Accessories**



Silencer

Filters

Heaters

Backdraft damper

Air damper

Clamps

Temperature controller

Speed switch

Sensor

### ■ Fan with electronic temperature and speed control module (Un option).

The ideal solution for ventilation of premises with high demands to permanent temperature control e.g. greenhouses.

A fan with an electronic temperature and speed module provides automatic control of impeller rotation speed (air flow) depending on the air temperature in the air duct or in the room.

The front panel of the electronic module has the following control knobs:

- controller for impeller speed presetting
- electronic thermostat operation threshold controller
- thermostat operation indicator.

### ■ Fan operation algorithm with electronic temperature and speed control module

Set the desired air temperature (thermostat threshold) by turning the thermostat control knob and the minimum rotation speed (air flow) by turning the speed control knob.

If the temperature rises and exceeds the set thermostat threshold, the automation switches the fan to the maximum rotation speed (maximum air flow).

When the air temperature drops below the set thermostat threshold, the automation switches the fan motor to the previously set rotation speed.

To prevent frequent switching of motor speeds in case when the temperature in the air duct is equal to the set temperature threshold, a speed switching delay has been introduced into the algorithm.

When the air temperature exceeds the set thermostat threshold by 2 °C, the fan switches to an increased speed.

The fan switches to the set (reduced) speed after the temperature drops below the set temperature threshold.

This algorithm is used to maintain the air temperature with an accuracy of 2 °C.

Fan speed changes are infrequent.

### Fan dimensions

Model	Dimensions [mm]				Weight [kg]
	∅D	B	L	H	
Stream 100/125 (spigot 100 mm)	100		752		
Stream 100/125 (spigot 125 mm)	125	253	679	273	5
Stream 150/160 (spigot 150 mm)	150		606		
Stream 150/160 (spigot 160 mm)	160		606		

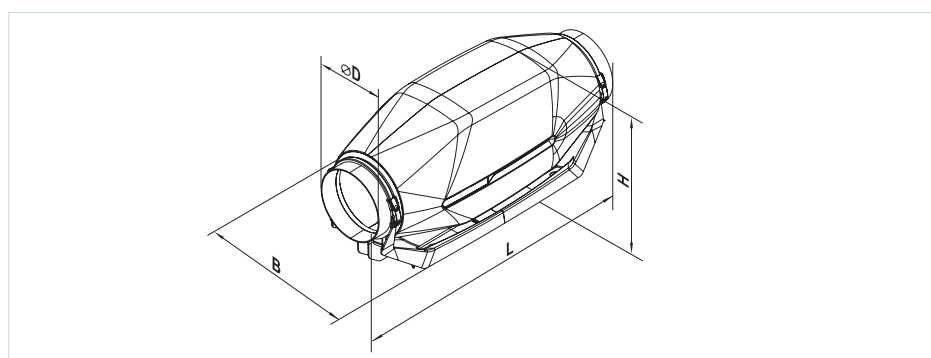

**Stream 100/125  
(spigot 100 mm)**



**Stream 100/125  
(spigot 125 mm)**



**Stream 150/160  
(spigot 150 mm, spigot 160 mm  
with a rubber seal)**

**SOUND-INSULATED FANS**
**Technical data**

Spigot diameter	Stream 100/125			Stream 100/125		
	100			125		
Speed	min.	med.	max.	min.	med.	max.
Voltage [V]	1~230			1~230		
Frequency [Hz]	50			50		
Power [W]	28	31	32	31	33	34
Current [A]	0.13	0.14	0.15	0.14	0.14	0.16
Maximum air flow [m <sup>3</sup> /h (l/s)]	114 (32)	147 (41)	220 (61)	164 (46)	216 (60)	320 (89)
RPM [min <sup>-1</sup> ]	1568	1952	2362	1552	1952	2356
Noise level at 3 m [dBA]	19	23	27	20	22	28
Transported air temperature [°C]	-25...+55			-25...+55		
Weight [kg]	5			5		
Protection rating	IPX4			IPX4		
Motor protection rating	IP20			IP20		

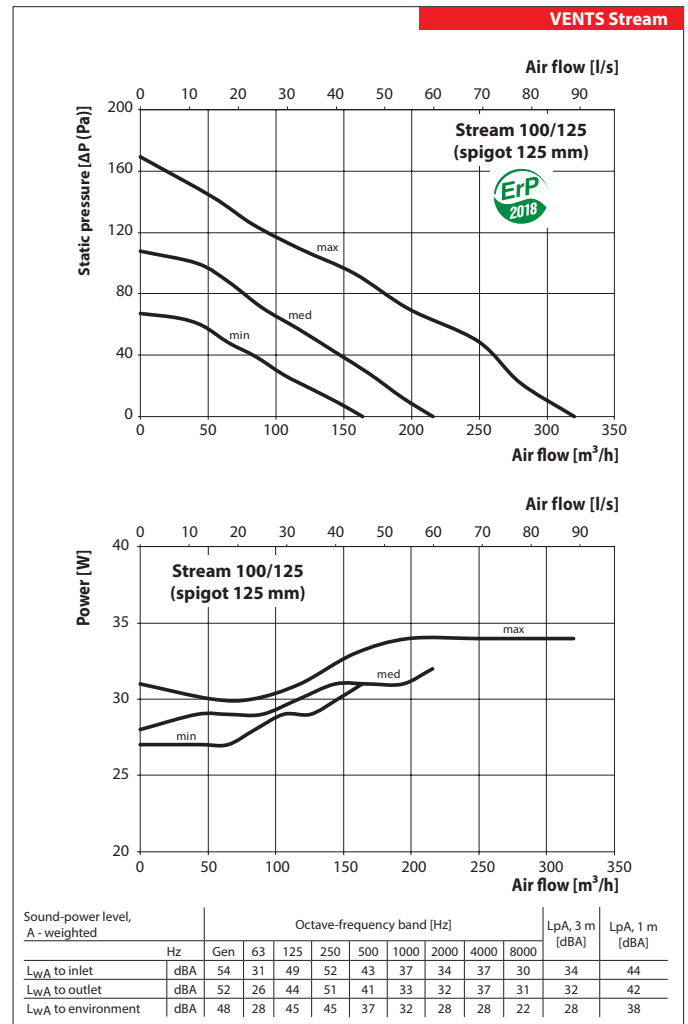
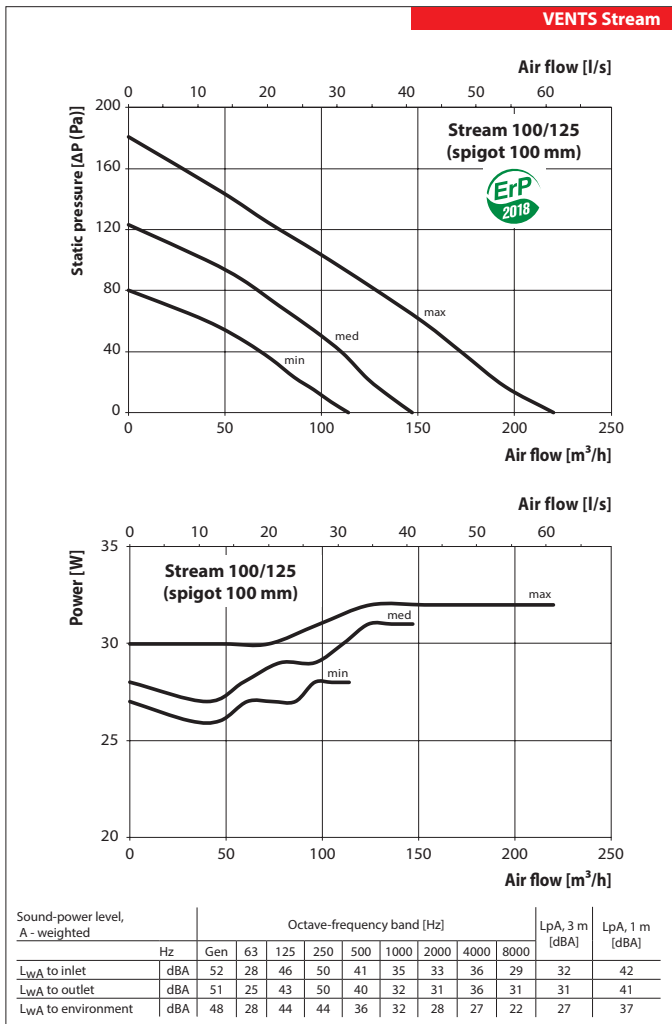

Stream 150/160			
Spigot diameter	150/160		
Speed	min.	med.	max.
Voltage [V]	1~230		
Frequency [Hz]	50		
Power [W]	25	46	51
Current [A]	0.20	0.21	0.24
Maximum air flow [m <sup>3</sup> /h (l/s)]	242 (67)	320 (89)	540 (150)
RPM [min <sup>-1</sup> ]	1982	2374	2738
Noise level at 3 m [dBA]	20	26	33
Transported air temperature [°C]	-25...+55		
Weight [kg]	5		
Protection rating	IPX4		
Motor protection rating	IP20		

